

JR
feel the difference!



XFG31

6-CHANNEL COMPUTER RADIO

TABLE OF CONTENTS

QUICK START	4	2. Connections	15
I. INTRODUCTION		2.1 Installation Requirements	15
1. Using This Manual	6	2.2 Connections	15
2. Features	6	3. Key Input and Display	16
2.1 Transmitter Features	6	4. Battery Alarm and Display	16
2.2 Receiver Features	6	5. Input Mode and Functions	17
2.3 Servo Features	7	5.1 Normal Display	17
2.4 Servo Layout	7	5.2 Direct Trim Access Display	17
3. Specifications	8	5.3 Mode Types	17
3.1 System Specifications	8	5.4 Throttle Cut	17
3.2 Transmitter Specifications	8	5.5 System Mode	18
3.3 Servo Specifications	8	5.6 Function Mode	18
3.4 Receiver Specifications	9	6. Functions (System Mode)	19
3.5 Charger Specifications	9	6.1 Data Reset	19
3.6 Airborne Battery Pack	9	6.2 Model Selection	20
4. Battery Charging	10	6.3 Wing Type Selection	20
4.1 Transmitter/Receiver	10	6.4 Model Name Entry	23
4.2 Charger	10	7. Functions (Function Mode)	24
5. Trainer System	11	7.1 Servo Reversing	24
		7.2 Dual Rate	25
		7.3 Sub Trim	26
		7.4 Travel Adjustment	27
II. XF631 MANUAL		8. Data Sheets	28
1. Transmitter Controls	12		
1.1 Control Identification and Location	12	III. IMPORTANT INFORMATION	
1.2 Receiver Channel Assignment/ Transmitter Throttle ALT	12	1. General Notes	31
1.3 Transmitter Rear	13	2. Daily Flight Checks	31
1.4 Control Stick Length Adjustment	13	3. Warranty Coverage	32
1.5 Direct Servo Control (DSC)	14	4. Repair Service Instructions	32
1.6 Neck Strap Attachment	14	5. Frequency Chart	33

INTRODUCTION TO THE XF631 RADIO SYSTEM

Thank you for purchasing the JR XF631 6-Channel Radio System. This unit has been designed to provide the modeler with a high-quality, user-friendly radio system that can be depended upon for years to come.

It's important that you carefully read this manual before attempting to operate your system. Please pay particular attention to Page 10, Introduction 4, "Battery Charging."

AMA INFORMATION

We strongly encourage all prospective and current R/C aircraft pilots to join the Academy of Model Aeronautics. The AMA is a non-profit organization that provides services to model aircraft pilots. As an AMA member you will receive a monthly magazine entitled *Model Aviation*, as well as a liability insurance plan to cover against possible accident or injury. All AMA charter aircraft clubs require

individuals to hold a current AMA membership prior to operation of their models. For further information you can contact the AMA at:

Academy of Model Aeronautics
5151 East Memorial Drive
Muncie, IN 47302
(317) 287-1256

XF631 QUICK START

In this manual you will find in-depth instructions that detail all the steps and procedures you should follow in order to program each of the XF631's features. For modelers who want to get into the air fast, we have provided Quick Start. Quick Start covers the basic programming information necessary to get you airborne. Later, when you want to learn more about specific features

of the XF631, turn to the appropriate pages(s) in this manual for more detailed programming information.

Note: Please charge the system batteries as indicated in step 4.1 before attempting the Quick Start setup and again before flying the model.

1 DIGITAL TRIM SETTINGS

Turn on the transmitter and check to ensure that the aileron, elevator, and rudder trim valves are set to the 0 (neutral) position.

Next, set the throttle trim valve to the full low (-40) position by pressing the throttle trim lever down.

2 SERVO REVERSING

A

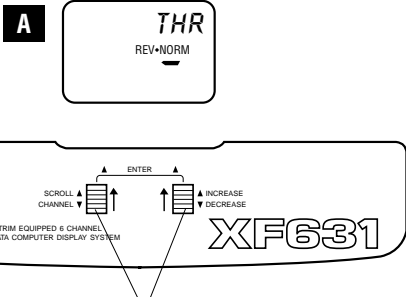

With the transmitter on, press the *Scroll* and *Increase* buttons upward simultaneously until a beep is heard.

B

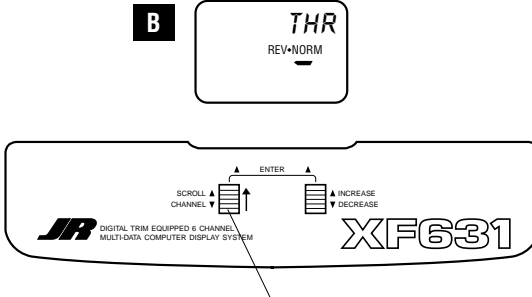

Press the *Scroll* button (if necessary) until "REVERSE-NORM" appears on the screen.

C

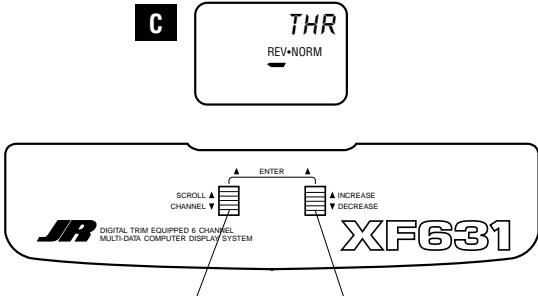

Press the *Channel* button to select the channel you want to reverse.

Press the *Increase* or *Decrease* button to reverse the direction of the channel you selected.

XF631 QUICK START

3

TRAVEL ADJUSTMENT

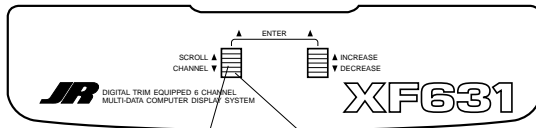
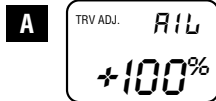

Press the *Scroll* button until "TRV ADJ" appears on the screen.

Press the *Channel* button to select the channel on which you want the travel adjusted.

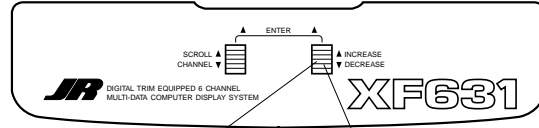

INCREASE

To increase the travel, move the stick (i.e. aileron) to the right then press the *Increase* button to adjust the right travel. Release the *Increase* button and move the same stick to the left. Press the *Increase* button to adjust the left travel.

DECREASE

To decrease the travel, move the stick (i.e. aileron) to the right then press the *Decrease* button to adjust the right travel. Release the *Decrease* button and move the same stick to the left. Press the *Decrease* button to adjust the left travel.

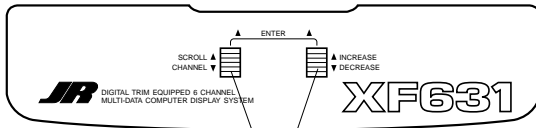

Press the *Scroll* and *Increase* buttons upwards simultaneously to return to the main screen and exit the Function mode.

Note: Before flying, check that the direction and travel of all control surfaces move correctly.

4

THROTTLE AUTO CUT

Before the initial start of your model, please check to ensure that when the *Throttle Cut* button is pressed, the engine's carburetor barrel will move to the fully closed (engine off) position.

This safety feature ensures that the engine can be shut off immediately in case of a problem or safety concern.

INTRODUCTION 1: Using This Manual

1

USING THIS MANUAL

The XF631 is a full feature introductory computer radio that can be used for airplanes.

A blank data sheet is included at the end of this manual. Once you have input all the necessary data

into your transmitter for a particular model, we strongly recommend that you write that information down on a copy of the data sheet provided. This is to ensure that, in the rare case of a memory failure, you will not lose your data.

INTRODUCTION 2: Features

2.1

TRANSMITTER FEATURES

- Easy-to-read LCD screen
- 3-model memory
- Trainer system compatible with most other JR FM radios
- 2 conveniently mounted direct-access programming levers
- Computer designed ergonomically styled case
- Adjustable stick length
- Dual rates for aileron and elevator
- Digital trims with Direct Access feature
- Throttle trim only affects idle position
- Two-speed scrolling—press and hold the appropriate button to scroll quickly or press and release to scroll in steps
- Flaperons mixing
- Delta wing mixing
- V-tail mixing
- Throttle cut safety feature

2.2

RECEIVER FEATURES

R700 Slimline Receiver

- The R700's extremely compact "slimline" design allows it to fit easily in limited spaces.
- An independent laboratory ranked the R700 receiver with JR's patented ABC&W circuitry as one of the best receivers ever tested in terms of 3IM, 2IM, adjacent channel rejection, signal-to-noise ratio, and on-channel capture point.
- A special "unwanted interference limiter" ignores signals outside of the R700's band width when the receiver is on and the transmitter is off.
- The limiter also prevents servos from random glitching when other transmitters are operating in close proximity.
- The electrical circuitry in the R700 is state-of-the-art surface mount technology (SMT). These SMT components draw less current, thus increasing flying time. Flush mounting of these components also reduces the risk of vibration, wear, and damage.
- The R700 is compatible with all JR FM-transmitting radios.

2.3 SERVO FEATURES

537 Servo

- An ultra-tight deadband amplifier ensures accurate neutral centering
- Low current drain
- Ball bearing supported output shaft with new wide spacing for improved precision
- An indirect drive feedback potentiometer gives additional protection from vibration

2.4 SERVO LAYOUT

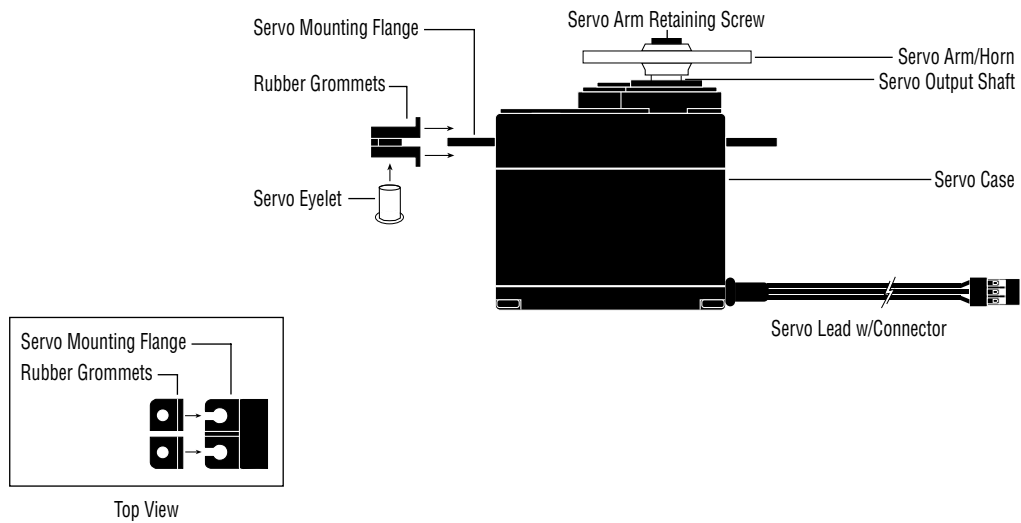

INTRODUCTION 3: Specifications

3.1 SYSTEM SPECIFICATIONS

TYPE	AIRPLANE
SYSTEM NAME	XF631
TRANSMITTER BODY	XF631
RECEIVER	R700
CHARGER	NEC-221
AIRBORNE BATTERY	4N-600
SERVOS	NES-537BB x 4
ACCESSORIES	Mini Switch 12" Aileron Extension Servo Accessories Instruction Manual

3.2 TRANSMITTER SPECIFICATIONS

TYPE	AIRPLANE
MODEL NUMBER	XF631
ENCODER	6-Channel Computer System
RF	72 MHz
MODULATION	PPM (FM)
OUTPUT POWER	Approximately 1 Watt
CURRENT DRAIN	200mA
POWER SOURCE	1.2V x 8 NiCad (9.6V) 600mAh
OUTPUT PULSE	1000-2000 (1500 Neutral)

3.3 SERVO SPECIFICATIONS

TYPE	537BB
TORQUE (oz/in)	43
SPEED (sec/60°)	.25
WEIGHT (oz)	1.37
SIZE (in) (W x L x H)	0.73 x 1.52 x 1.32
BB	YES
MOTOR	3-Pole Ferite

INTRODUCTION 3: Specifications continued

3.4 RECEIVER SPECIFICATIONS

TYPE	R700 FM
MODEL NUMBER	NER-700
TYPE	7-Ch/FM Slimline w/ABC Circuitry
FREQUENCY	50/53/72MHz
SENSITIVITY (Microseconds)	5 μ s Minimum
SELECTIVITY	8KHz/50dB
WEIGHT (oz)	.64 oz
SIZE (in) (W x L x H)	1.84 x 0.98 x 0.61
RECEIVER ANTENNA	39" For All Aircraft Frequencies

3.5 CHARGER SPECIFICATIONS

TYPE	AIRPLANE
MODEL NUMBER	NEC-221
INPUT VOLTAGE	AC 100-120V
OUTPUT CURRENT	50mAh TX/50mAh RX
CHARGING TIME	15 Hours

3.6 AIRBORNE BATTERY PACK

TYPE	AIRPLANE
MODEL NUMBER	4N-600
VOLTAGE	4.8V
SIZE (in) (W x L x H)	2.24 x 0.59 x 2.05
WEIGHT (oz)	3.3

INTRODUCTION 4: Battery Charging

4.1 TRANSMITTER / RECEIVER

It is imperative that you fully charge both the transmitter and the receiver battery packs prior to each day of flying. For the initial charge, leave the charger and batteries hooked up for 20-24 hours in order to fully charge both battery packs to peak capacity. For subsequent charges, leave the charger and batteries hooked up overnight (approximately 16 hours).

The charger supplied with this system is designed to recharge your transmitter battery at a rate of 50mA. The receiver battery pack will charge at 50mA for the 600mAh battery pack.

Transmitter Only

The center pin on all JR remote control systems is **negative**. Therefore, the center pin on all JR chargers is negative, not positive. This is different from any other manufacturers' chargers and radio systems. Beware of improper connections based on "color code" wire leads as they **do not apply** in this instance. You must make certain that the center pin of your JR transmitter is always connected to the negative voltage for correct polarity hookup.

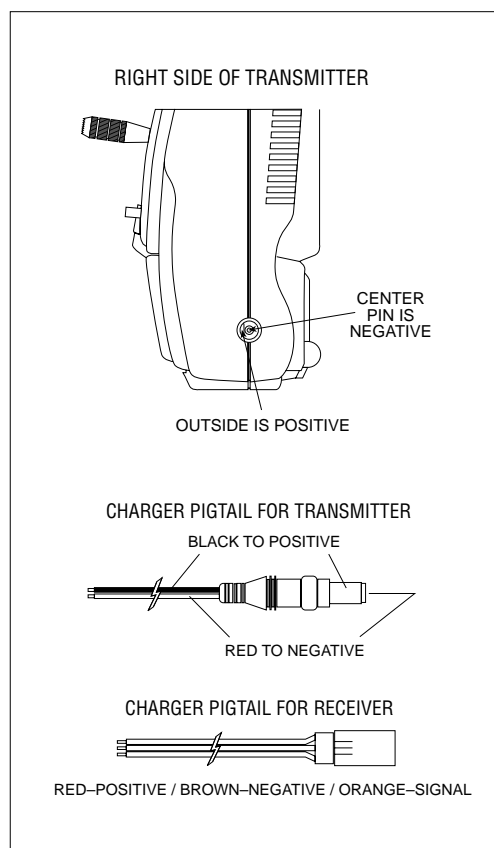

4.2 CHARGER

The pilot lamps should always be on during the charging operation. If they are not, make sure you have turned off both the transmitter and receiver.

Do not use the charger for equipment other than JR. The charging plug polarity may not be the same, and equipment damage may result.

Do not use other manufacturers' after-market accessories that plug into the transmitter's charging jack. If you do, any damage that results will not be covered by warranty. If you are unsure of compatibilities with your radio, seek expert advice before doing anything to avoid possible damage. During the charging operation, the charger's temperature is slightly elevated. This is normal.

INTRODUCTION 5: Trainer System

5 TRAINER SYSTEM

The XF631 features a built-in trainer system. The transmitter can be used as either a master (trainer) or as a slave (trainee). The XF631 is compatible with all

other current JR radios that have built-in trainer systems. An optional trainer cord (JRPA130) is needed.

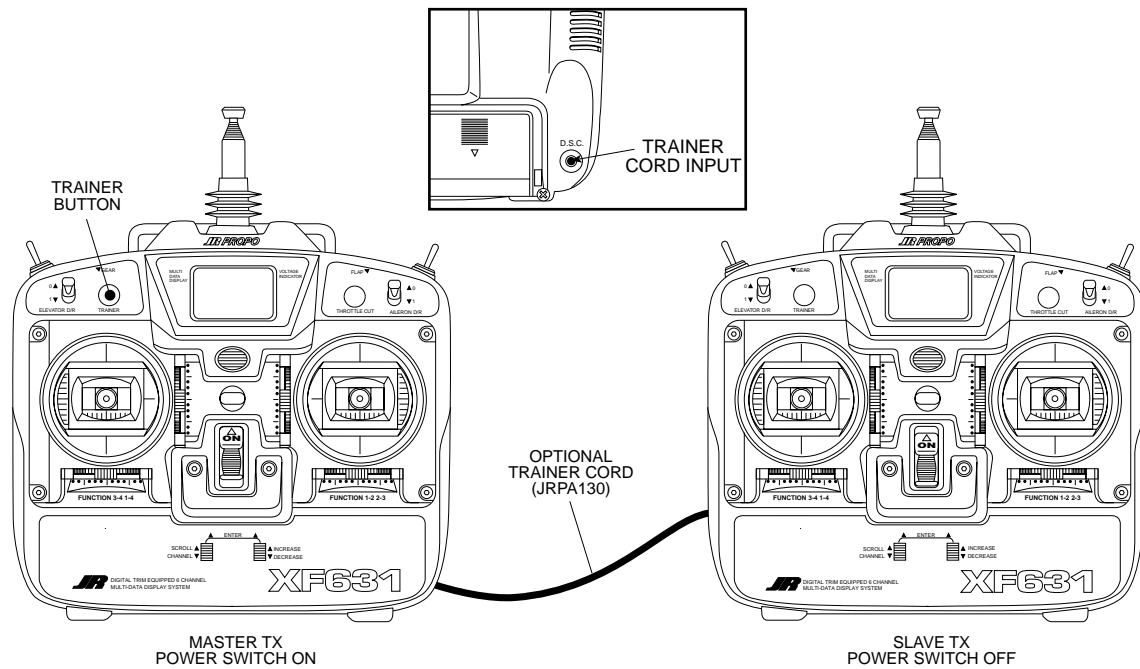

Operating the Trainer System

1. Match the servo reversing, sub-trims, travel adjust, and trims of both radios.
2. Plug the optional trainer cord into both transmitters.
3. Turn on the master transmitter.
4. Test all the control functions on your aircraft with the master radio.
5. Push the *Trainer* button on the master transmitter and check all the control functions with the slave radio.

Note: The slave radio must be left off.

CHAPTER 1: Transmitter Controls

1.1

CONTROL IDENTIFICATION AND LOCATION • Mode II

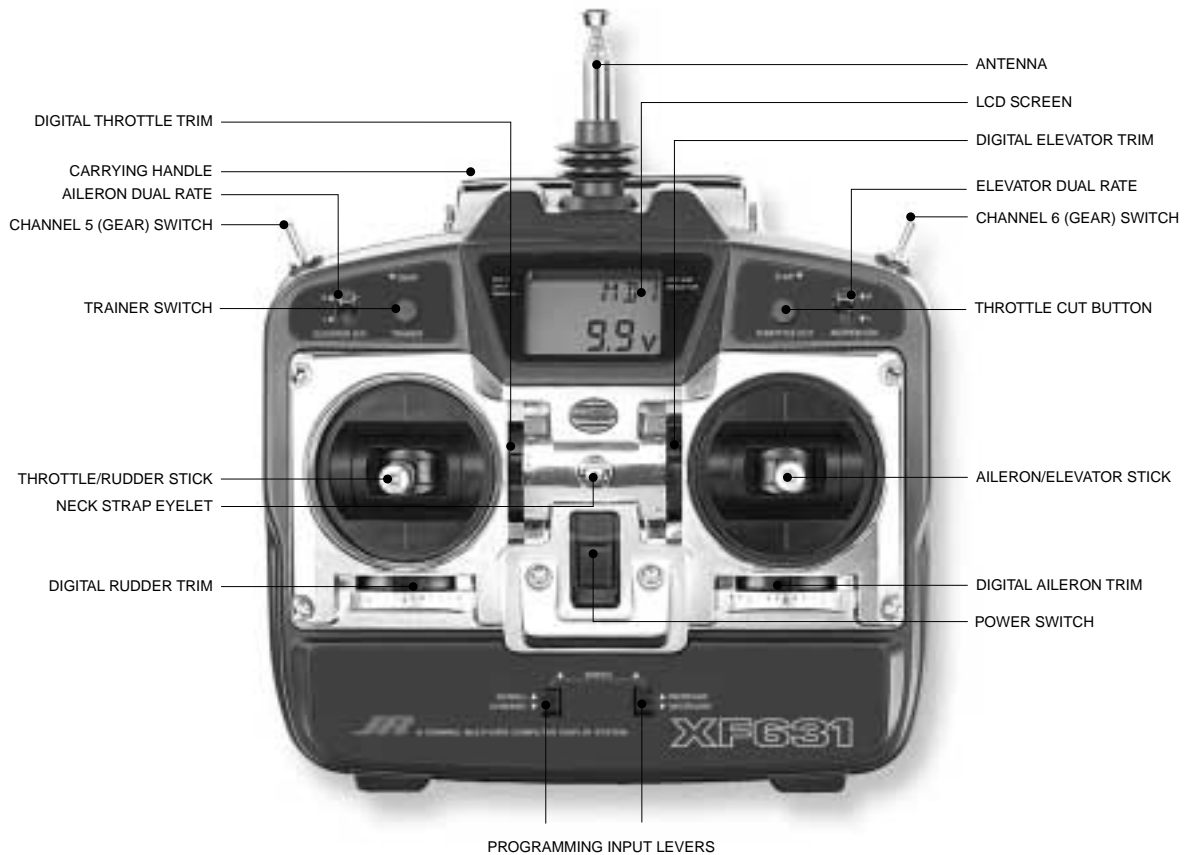

1.2

RECEIVER CHANNEL ASSIGNMENT/TRANSMITTER THROTTLE ALT

1. THRO: Throttle Channel
2. AILE: Aileron Channel
3. ELEV: Elevator Channel
4. RUDD: Rudder Channel
5. GEAR: Gear Channel
6. AUX 1: Flap Channel

Transmitter Throttle ALT

The throttle ALT function makes the throttle stick trim active only when the throttle stick is less than half throttle. This gives easy, accurate idle adjustments without affecting the high throttle position.

CHAPTER 1: Transmitter Controls continued

1.3 TRANSMITTER REAR

Note: Your transmitter has a 5-year lithium battery to protect your preprogrammed data against main transmitter battery failure. If your system reads 0.0V or has an unfamiliar display (service mode), or your

data resets to the factory defaults, return your transmitter to Horizon Service Center (see page 28) for a lithium battery replacement.



1.4 CONTROL STICK LENGTH ADJUSTMENT

To adjust the control stick length, use a 2 mm Allen wrench to unlock the set screw located inside the end of the control stick. Turn the set screw counterclockwise to loosen it, then turn the knurled portion of the stick to adjust the length. Counterclockwise will lengthen the stick and clockwise will shorten it. After the control stick(s) has been adjusted to suit your flying style, tighten the set screw.

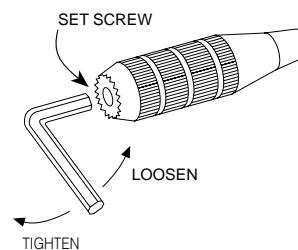

1.5 DIRECT SERVO CONTROL (DSC)

For proper DSC hook-up and operation:

1. Leave the transmitter power switch off. The transmitter will not transmit any radio frequency (RF) in this position.
2. Plug the optional DSC cord (JRPA132) into the DSC port in the rear of the transmitter.
3. The encoder section of the transmitter will now be operational and the LCD display will be lit.
4. Plug the other end of the DSC cord into the receiver charge receptacle. Turn on the switch harness.

Note: When installing the optional charging jack (JRPA024), be sure to hook the charging jack receptacle securely into the switch harness charge cord.

Why you should use the DSC function:

1. The DSC enables you to check the control surfaces of your airplane without drawing the fully operational 200mAh from your transmitter battery pack. Instead, you will only draw 70mAh when using the DSC function.

Note: You will need to purchase (separately) both the DSC cord (JRPA132) and the JR Deluxe Switch Harness (JRPA001) to make use of the XF631 DSC function.

2. The DSC function allows you to make final adjustments to your airplane without transmitting any radio signals. Therefore, if another pilot is flying on your frequency, you can still adjust your aircraft and not interfere with the other aircraft.

Note: Under no circumstances should you attempt to fly your aircraft with the DSC cord plugged in! This feature is for bench checking your aircraft only.

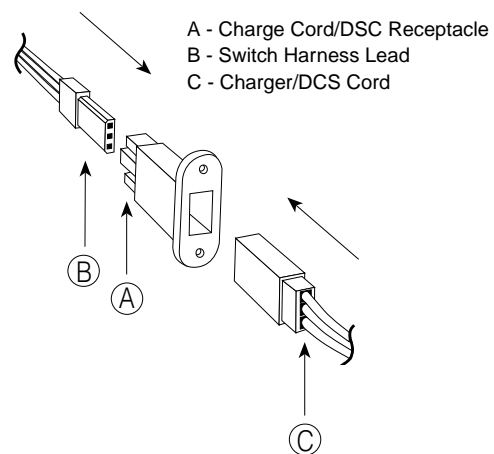

1.6 NECK STRAP ATTACHMENT

There is an eye hook on the front of the transmitter for attaching an optional neck strap (JRPA023). The eye hook is precisely positioned (see Section 1.1)

so that the transmitter will be perfectly balanced when a neck strap is used.

CHAPTER 2: Connections

2.1 INSTALLATION REQUIREMENTS

It is important to correctly install the radio system in your model. Please read and carefully follow the suggestions listed below.

1. For added protection, wrap the RX and the RX NiCad in foam rubber that is at least 1/4" thick.
2. Run the RX antenna through the fuselage and make sure it is fully extended. Never cut or bundle your RX antenna — this will decrease range and performance.
3. Rubber servo grommets are included with your radio system and should be installed in the servo flanges. The servos should then be mounted on either hardwood rails or a plywood tray with the mounting screws provided. **Do not overtighten the mounting screws.** The flange of the brass eyelets should face down (toward the wood).
4. All servos must be able to move freely over the full range of their travel. Make sure the linkages do not impede servo travel. A stalled servo will drain the battery pack within a few minutes.
5. Before installing servo output arms, make sure the servo is in its neutral position.
6. In the case of gas-powered model aircraft, mount the receiver power switch on the side of the fuselage opposite the muffler to protect the switch from exhaust residue. With other types of models, mount the switch in the most convenient place. Make sure that the switch operates freely and is capable of traveling its full distance.
7. **With your model sitting on the ground and the transmitter antenna collapsed, check that your system works at a distance of 75 to 100 feet.**

If your system stops functioning at a distance that is shorter than listed above, please contact the Horizon Service Center for further information prior to flying your model.

2.2 CONNECTIONS

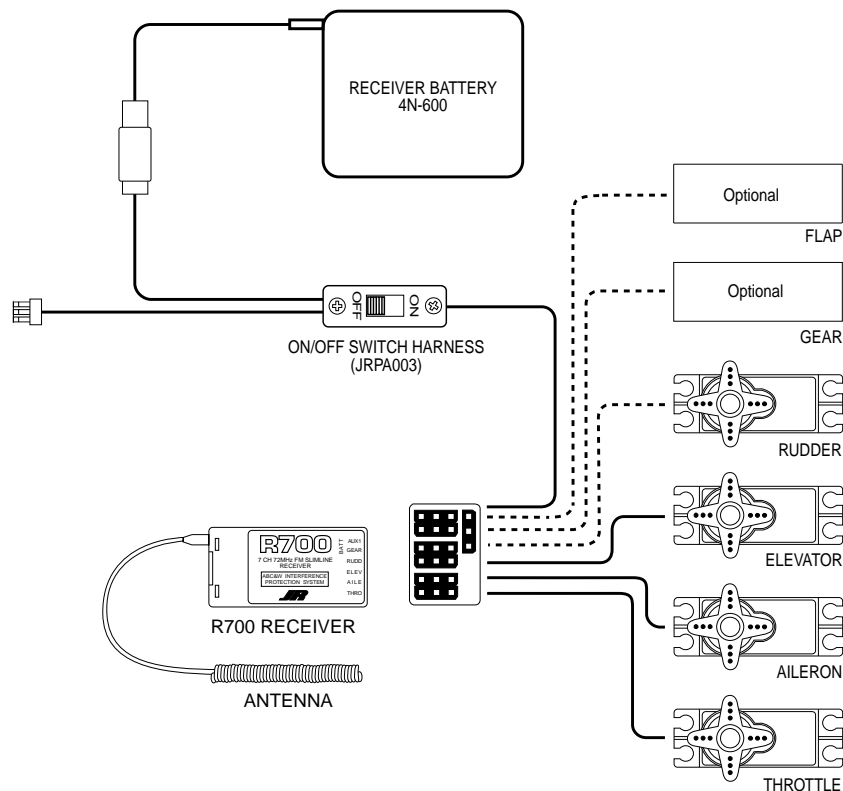

CHAPTER 3: Key Input and Display

3

KEY INPUT AND DISPLAY

Two input keys are located at the lower right and left faceplate of the XF631 transmitter. The keys are used to access and program the transmitter. Each key can be moved up or down using your thumbs.

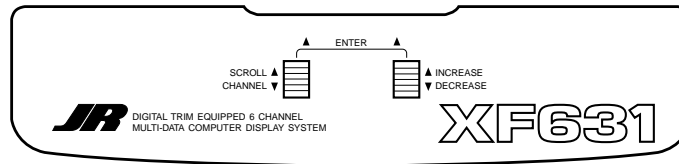

Left button up.....*Scroll* — Used to advance through the menus.

Left button down...*Channel* — Used to advance through the channels or features in a given function.

Right button up.....*Increase* — Increases value or changes setting (e.g., Reverse Normal).

Left button down.....*Decrease* — Decreases value or changes setting. (e.g., Reverse Normal).

CHAPTER 4: Battery Alarm and Display

4

BATTERY ALARM AND DISPLAY

When the transmitter battery drops below 9.0 volts, the display will start to flash BAT and an audible alarm will sound for 8 beeps. These warnings mean you should land your aircraft immediately.

Note: During the period that the battery alarm is flashing, the input buttons will not function. If you are currently in the function mode, the transmitter will exit automatically and return to the normal display (see Section 5.1).

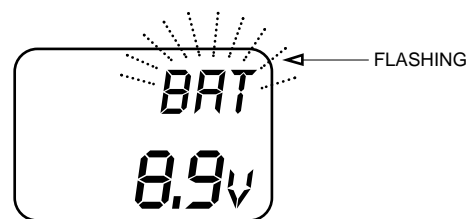

CHAPTER 5: Input Mode and Functions

5.1 NORMAL DISPLAY

When the power switch is turned on, the screen will read as shown here in the diagram. This screen is referred to as the normal display.

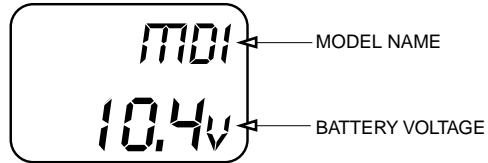

5.2 DIRECT TRIM ACCESS DISPLAY

The Direct Trim function of the XF631 can be accessed through the use of any of the 4 digital trims levers (throttle, aileron, elevator, or rudder). When a trim input is given, the screen will automatically change to show the trim value for that particular channel. Once the trim adjustment has been made, the screen will automatically return to the previous screen setting after 2-3 seconds. The maximum trim value for each channel is +/- 40 in increments of 2.

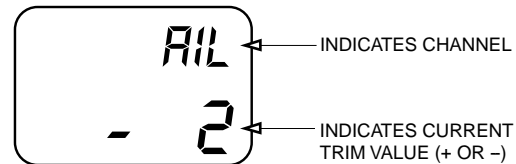

5.3 MODE TYPES

The XF631 features two types of programming paths. System mode includes programming functions that are initially adjusted when the model is first set up, like selecting wing type or the model, and is seldom accessed after the initial setup. System modes include:

- MODEL RESET
- MODEL SELECT
- WING TYPE MIXING
- V-TAIL MIXING
- MODEL NAME

Function mode includes programming that is more frequently changed, sometimes at the flying field.

Function Modes include:

- SERVO REVERSING
- DUAL RATES
- SUB-TRIM
- TRAVEL ADJUST

5.4 THROTTLE CUT

Your XF631 incorporates a special *Throttle Cut* button located on the upper right face of the transmitter. This feature is designed to immediately override any current throttle/trim position and will immediately return the throttle servo to the full low position. This feature will allow the engine to be automatically stopped in case of emergency, or in the event of a crash. When adjusting your throttle linkage, please

check to ensure that when the *Throttle Cut* button is pushed, the throttle servo will move the carburetor barrel to the full closed position.

Note: In some cases it will be necessary to adjust the engines barrel stop screw so that the carburetor can be fully closed. Please refer to your engine instructions for more detail.

CHAPTER 5: Input Mode and Functions continued

5.5 SYSTEM MODE

To enter the System mode, press the *Scroll* and *Increase* buttons up simultaneously while you turn on the transmitter. You can now select any of four system mode functions shown here in the flow chart. To exit the System mode, press the *Scroll* and *Increase* buttons simultaneously or turn off the transmitter. Press up the *Scroll* button to move through the System mode functions. Information for each function is located on the page number listed next to the function name.



Power Switch ↑ To enter System Setup mode, press both programming levers up and turn on the Power switch.

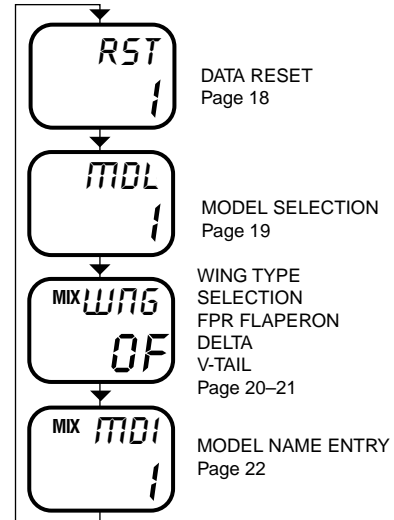
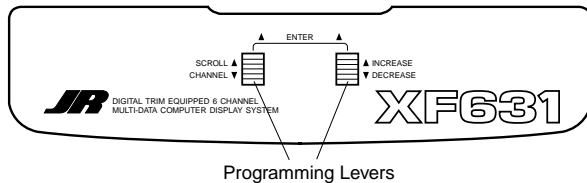

5.6 FUNCTION MODE

To enter the Function mode, turn on the transmitter. Press the *Scroll* and *Increase* buttons up simultaneously until a beep is heard. The display will change accordingly and show the last active function. Press the *Scroll* button up to scroll down through the functions one by one as shown in the flowchart at left. Once the appropriate function is selected, use the *Channel* button to select the appropriate channel. Use the *Increase* and *Decrease* buttons to adjust the values displayed on the screen.



Power Switch ↑ To enter Function mode, turn on the Power switch and then press both programming levers up.

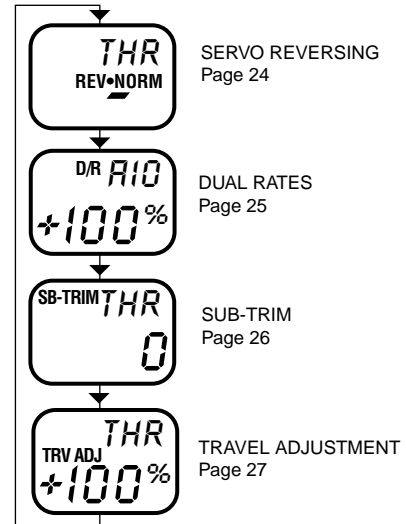
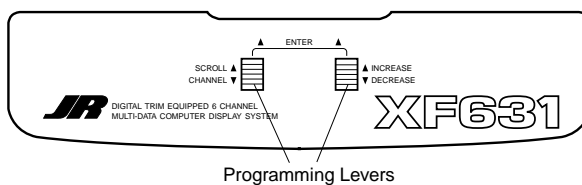

CHAPTER 6: Functions (System Mode)

6.1 DATA RESET • System Mode

The data reset function allows you to reset all the programming in the selected model (1, 2, or 3) to the factory settings. Before using the data reset function, it's important to enter the model selection function

and select the desired model number (1, 2, or 3) for which you want to reprogram to the factory settings. The model selection function is described in Section 6.2.

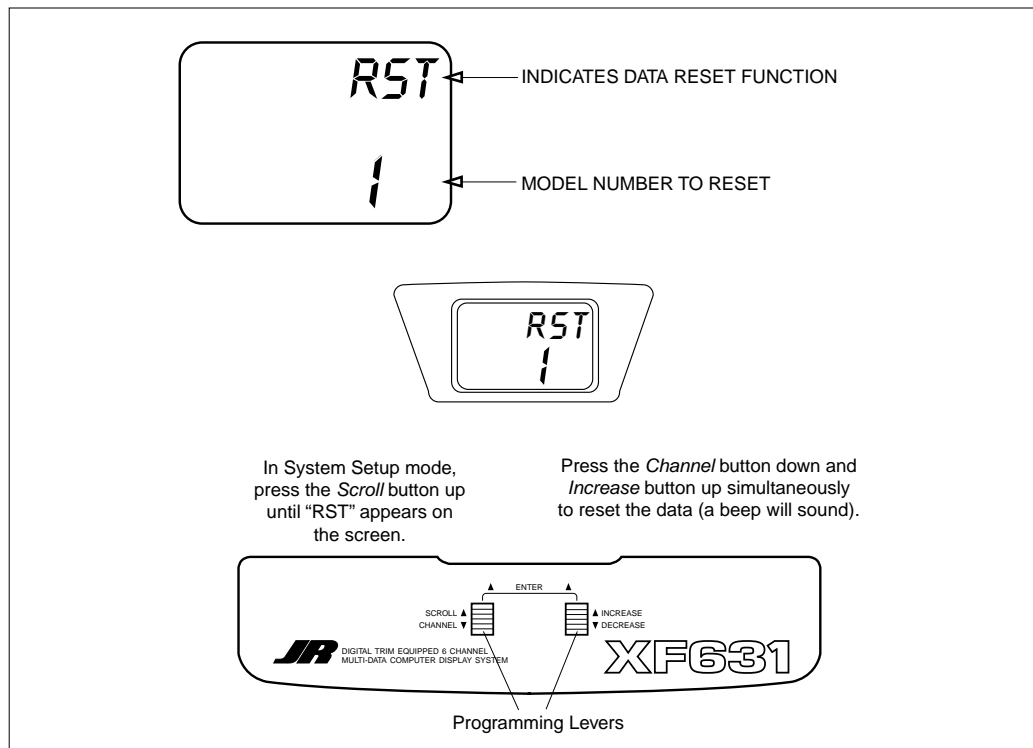

Accessing the Data Reset Function

1. Press the *Scroll* and *Increase* buttons up simultaneously and hold.
2. Turn on the transmitter to enter the System mode.
3. Press the *Scroll* button up until "RST" appears on the screen.
4. Press the *Channel* and *Increase* buttons simultaneously to reset the data. (To confirm that the selected model's programming has been reset, a beep will sound and the model number will momentarily disappear from the screen.)
5. Press the *Scroll* button to access the model select function.
6. To exit, press the *Scroll* and *Increase* buttons up simultaneously.

CHAPTER 6: Functions (System Mode) continued

6.2 MODEL SELECTION • System Mode

The XF631 has memory for 3 models.

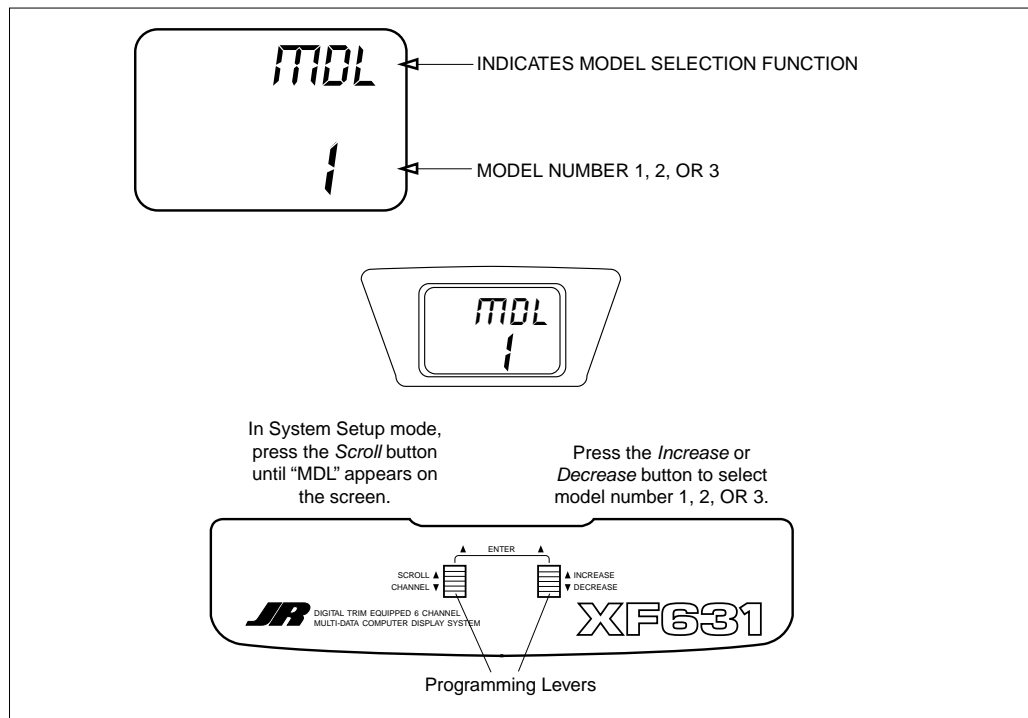

Accessing the Model Selection Function

1. Press the *Scroll* and *Increase* buttons up simultaneously and hold.
2. Turn on the transmitter to enter the System mode.
3. Press the *Scroll* button until "MDL" appears on the screen.
4. Press the *Increase* or *Decrease* button to select model number 1, 2, or 3.
5. Press the *Scroll* button to access the wing type entry function.
6. To exit, press the *Scroll* and *Increase* buttons up simultaneously.

6.3 WING TYPE SELECTION • System Mode

Flaperon, V-tail, and Delta mixing are available for specialty aircraft that require those functions. The flaperon feature mixes flaps with ailerons so the ailerons can be drooped for takeoffs and landings while still functioning fully as ailerons. V-tail mixing combines rudder and elevator for V-tail operations. The Delta wing function allows the aileron to also act as the elevator, while retaining independent use of both functions. The Delta wing function allows the ailerons to also act as the elevator, while retaining independent use of both functions.

Flaperon Setup

When using flaperon mixing, two servos (one for each aileron) must be used. Connect the left aileron servo to channel #6 (Flp/Aux 1) and the right aileron servo to channel #2 (Aile) in the receiver. Individual functions (e.g., servo reversing, sub-trims, etc.) are still available for each of the channels. Use sub-trims for individual neutral adjustment.

Note: When flaperon is selected, it is necessary to reduce the travel adjust values of channel #6 0% in each direction to prevent servo over-travel (binding). Please refer to section 7.3 for travel adjust information.

V-Tail

V-Tail mixing requires two servos. Connect the left tail servo to channel #3 (Elev) and the right tail servo to channel #4 (Rudd) in the receiver. Individual functions (e.g., servo reversing, sub-trims, etc.) are available for each servo. Use sub-trims for individual neutral adjustments described in Section 7.2. V-Tail elevator travel is adjusted by elevator and rudder travel adjust.

Delta Wing Mixing

Delta or elevon mixing, as it is commonly known, is the final wing mixing selection in your XF631. This style of aircraft also employs two wing servos. However, in essence, there is not an elevator present. Instead, at an elevator stick input, the two wing servos function in conjunction with one another in the same direction to create an up/down movement of the aircraft. Also, when an aileron control is given, the two wing servos move in opposite directions to function as ailerons as well.

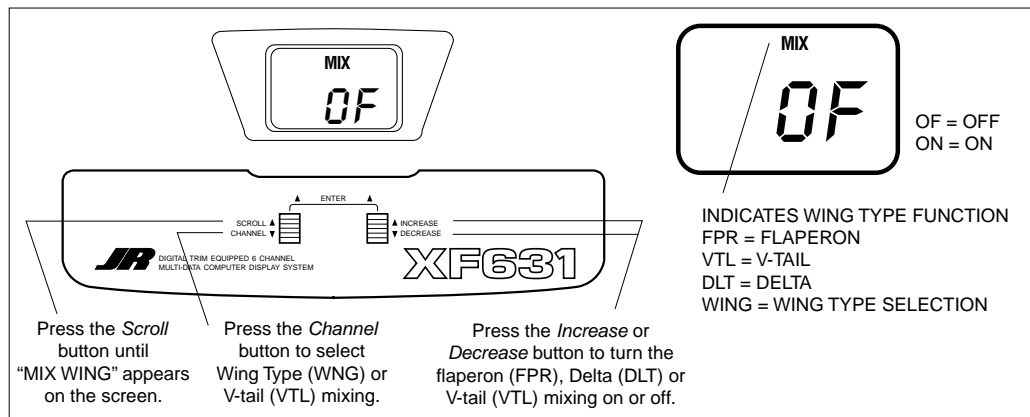

Accessing the Wing Type Selection Function

1. Press the *Scroll* and *Increase* buttons up simultaneously and hold.
2. Turn on the transmitter to enter the System mode.
3. Press the *Scroll* button until the "MIX WNG" appears on the screen.
4. Press the *Channel* button to select either the wing type (WNG) or V-tail (VTL) mode.
5. Press the *Scroll* button to access the model name function.
6. To exit, press the *Scroll* and *Increase* buttons up simultaneously.

CHAPTER 6: Functions (System Mode) continued

6.3 WING TYPE SELECTION • System Mode (continued)

To Activate Flaperon (FPR) Mixing (Wing Type Mode)

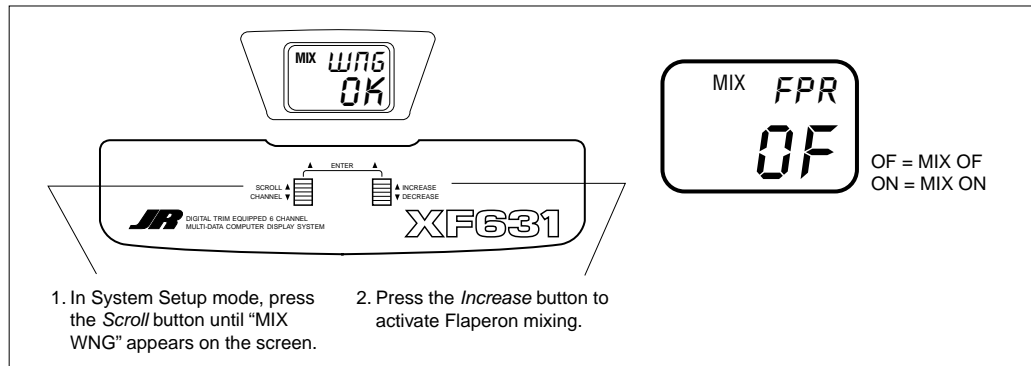

1. In System Setup mode, press the *Scroll* button until "MIX WNG" appears on the screen.

2. Press the *Increase* button to activate Flaperon mixing.

OF = MIX OF
ON = MIX ON

To Activate Delta Wing (DLT) Mixing (Wing Type Mode)

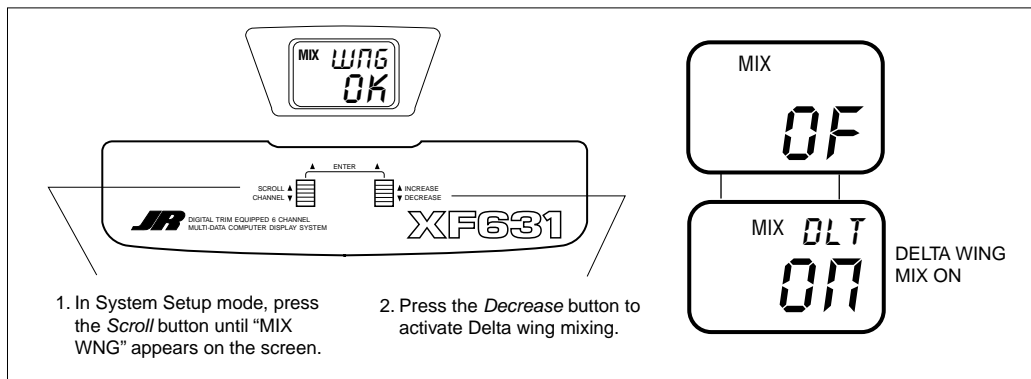

1. In System Setup mode, press the *Scroll* button until "MIX WNG" appears on the screen.

2. Press the *Decrease* button to activate Delta wing mixing.

DELTA WING
MIX ON

To Activate V-Tail (VTL) Mixing

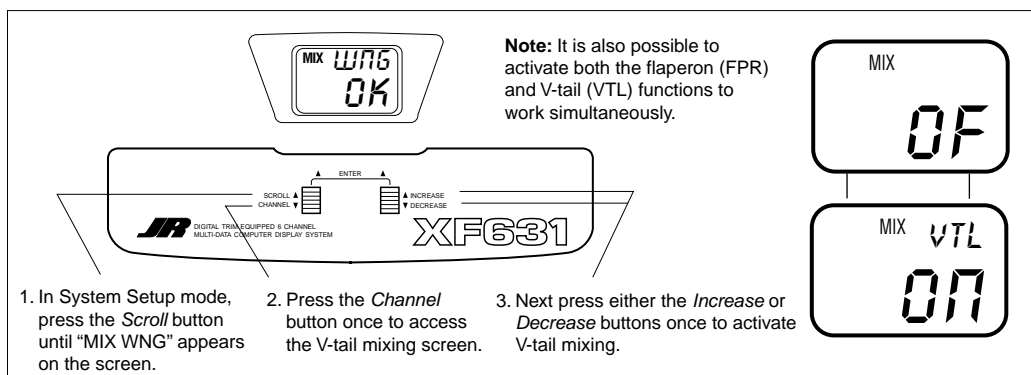

Note: It is also possible to activate both the flaperon (FPR) and V-tail (VTL) functions to work simultaneously.

1. In System Setup mode, press the *Scroll* button until "MIX WNG" appears on the screen.

2. Press the *Channel* button once to access the V-tail mixing screen.

3. Next press either the *Increase* or *Decrease* buttons once to activate V-tail mixing.

CHAPTER 6: Functions (System Mode) continued

6.4 MODEL NAME ENTRY • System Mode

The XF631 allows a 3-character name to be input for each of the 3 models available. The current model will be displayed in the normal display. This feature

is useful to help identify different aircraft types or model setups.

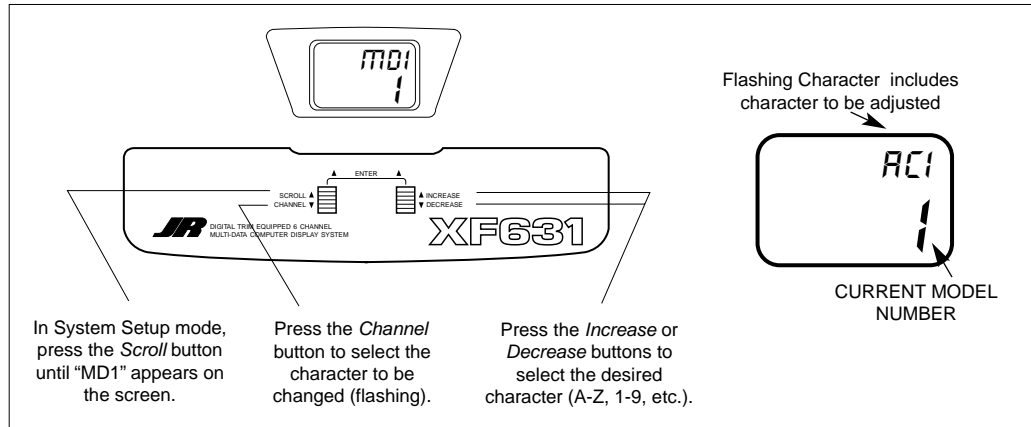

Accessing the Model Name Entry Function

1. Press the *Scroll* and *Increase* buttons up simultaneously and hold.
2. Turn on the transmitter to enter the System mode.
3. Press the *Scroll* button until "MD1" appears on the screen.
4. Press the *Increase* or *Decrease* buttons to select the correct letter/number for the first character (flashing).
5. To adjust the remaining 2 characters, press the *Channel* button until the desired character to be adjusted is flashing.
6. Press the *Scroll* button to access the modulation select function.
7. To exit, press the *Scroll* and *Increase* buttons up simultaneously.

CHAPTER 7: Functions (Function Mode)

7.1 SERVO REVERSING • Function Mode

Servo reversing is a very convenient function used in the setup of a new aircraft. It is used to change the direction of servo rotation in relation to the

corresponding stick movement. Servo reversing is available for all channels.

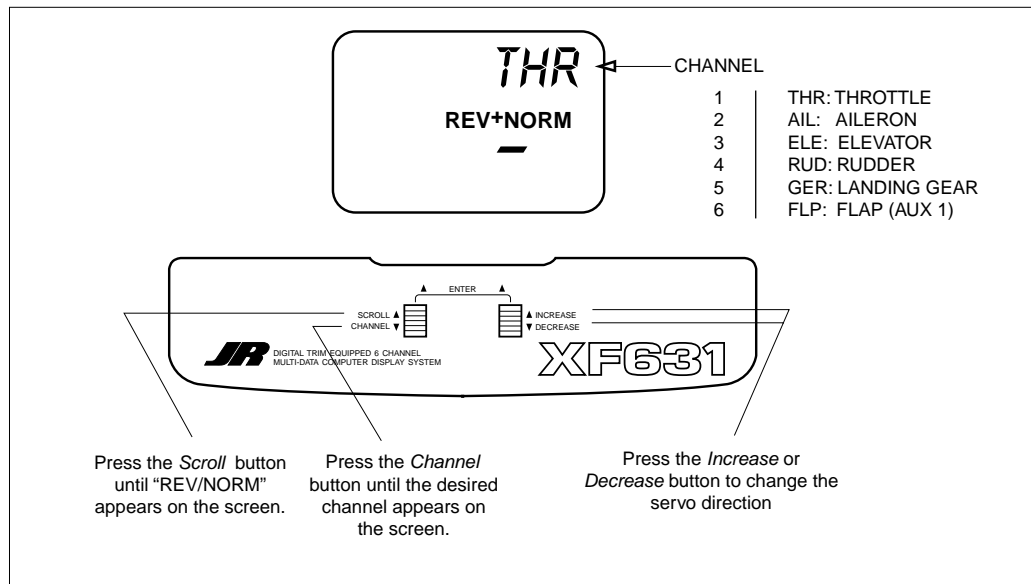

Accessing the Servo Reversing Function

1. Turn on the transmitter.
2. Press the *Scroll* and *Increase* buttons up simultaneously to enter the Function mode.
3. Press the *Scroll* button until "REV/NORM" appears on the screen.
4. Press the *Channel* button until the desired channel appears on the screen.
5. Press the *Increase* or *Decrease* button to change the servo direction.
6. Press the *Scroll* button to access the sub-trim function.
7. To exit, press the *Scroll* and *Increase* buttons up simultaneously.

7.2 DUAL RATE • Function Mode

Dual rate is available for the aileron and elevator channels. The purpose of this function is to allow for in-flight selection of two preset servo travels for each of these channels. The amount of travel is adjustable from 0-125%. The factory settings for both switch positions (0 and 1) is 100%. Either position may be selected as the low or high rate by placing the switches in the desired position and adjusting the value for that position. Different types of maneuvers

require varying amounts of control movements. Snap rolls require large control movements, while smooth maneuvers like long slow rolls are best performed with smaller control movements. Dual rates allow you to change the control movements in flight at the flip of a switch. This allows you to execute maneuvers requiring both radical control movements and small control movements during a single flight.

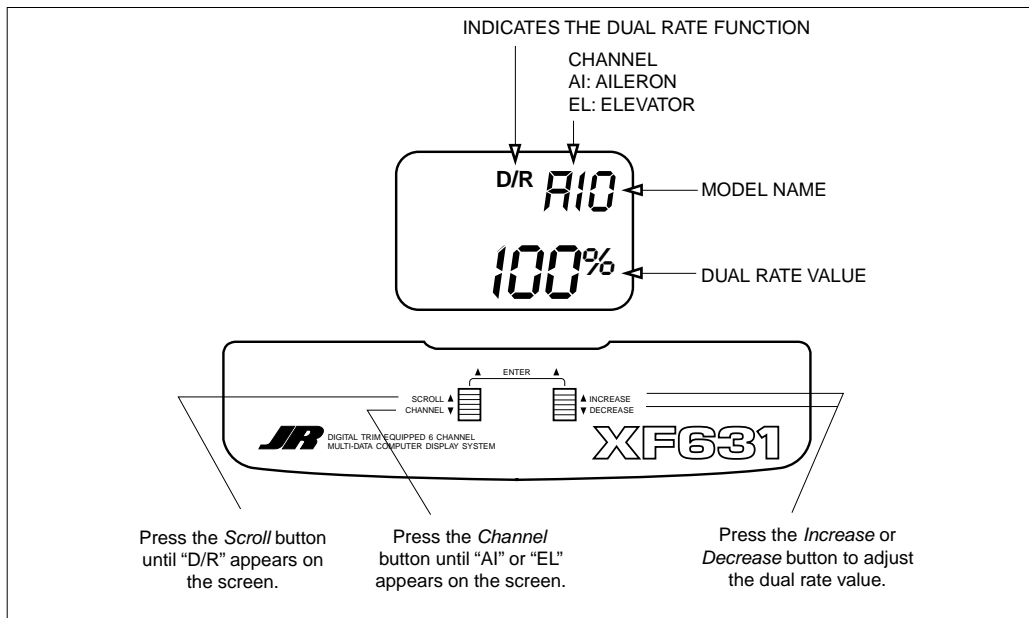

Accessing the Servo Reversing Function

1. Turn on the transmitter.
2. Press the *Scroll* and *Increase* buttons simultaneously to enter the Function mode.
3. Press the *Scroll* button until "D/R" appears on the screen.
4. Press the *Channel* button until the desired channel appears on the screen. (AI = aileron or EL = elevator).
5. The number that appears directly to the right of the selected channel is the switch position. There are two switch positions, 0 and 1, for each of the channels. A "0" will appear when the selected dual rate switch is in the uppermost position and a "1" when the selected switch is in the lower position.
6. The number in the center of the screen indicates the current dual rate value for the selected switch position and channel. Press the *Increase* or *Decrease* button to adjust the dual rate value (0-125%).
7. After adjusting the value for the 0 switch position, change to the 1 switch position and adjust the rates.
8. Press the *Channel* button to select the other channel and adjust the dual rate value for both switch positions.
9. To exit, press the *Scroll* and *Increase* buttons simultaneously.

7.3 SUB-TRIM • Function Mode

Sub-trim is an electronic trim that is available for each of the 6 channels. Sub-trim is particularly useful as it allows the digital trim levers to be returned to their neutral positions by adjusting /changing the servo's neutral position electronically, without the need to mechanically adjust the specific control linkage. This allows the same digital trim lever settings between the two models you can control with this radio system. Sub-trim can also allow additional trim travel when digital trims do not provide enough movement.

Note: It is recommended to use as little sub-trim as possible for adjustment. If more than 20–30 points are required, it is suggested that a mechanical linkage adjustment be performed.

Note: Prior to making final subtrim adjustments, please check to make sure that the digital trim values for aileron, elevator, and rudder are set to the neutral position. Throttle trim value should be set to the -40 position.

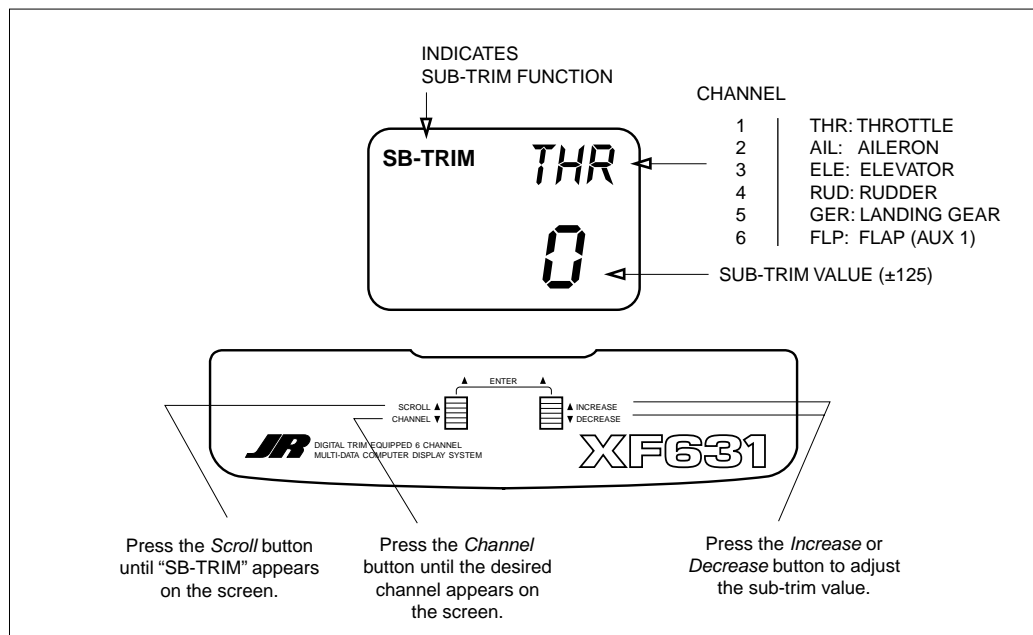

Accessing the Sub-Trim Function

1. Turn on the transmitter.
2. Press the *Scroll* and *Increase* buttons up simultaneously to enter the Function mode.
3. Press the *Scroll* button until "SB-TRIM" appears on the screen.
4. Press the *Channel* button until the desired channel appears on the screen.
5. Press the *Increase* or *Decrease* button to establish the desired amount of sub-trim.
6. Press the *Scroll* button to access the travel adjustment function.
7. To exit, press the *Scroll* and *Increase* buttons up simultaneously.

7.4 TRAVEL ADJUSTMENT • Function Mode

The amount of servo travel is adjustable for each direction for each of the 6 channels individually. The adjustment range is from 0% to 150%. Travel adjustment is factory set at 100% for all channels. The travel adjustment value displayed on the screen

depends on the position of the stick or switch (e.g., flap switch, gear switch). This function is useful either to maximize control surface travel or to reduce travel to eliminate servo binding without the need for mechanical adjustment.

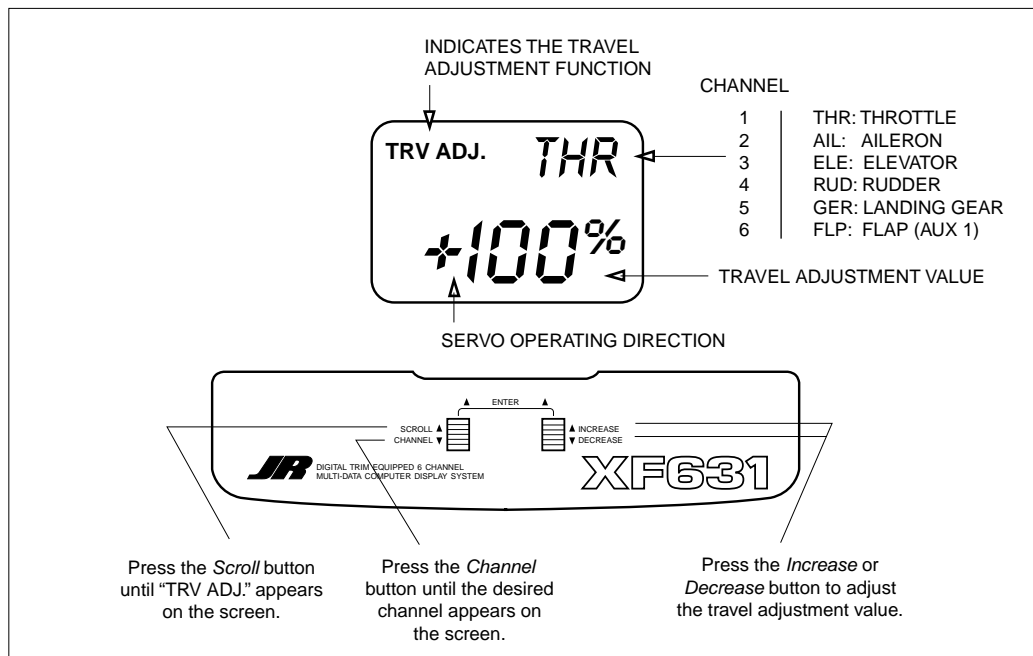

Accessing the Travel Adjustment Function

1. Turn on the transmitter.
2. Press the *Scroll* and *Increase* buttons up simultaneously to enter the Function Mode.
3. Press the *Scroll* button until "TRV ADJ." appears on the screen.
4. Press the *Channel* button until the desired channel appears on the screen.
5. Move the selected channel stick or switch in the direction that you want to adjust the travel.
6. Press the *Increase* or *Decrease* button to achieve the desired travel. Move the stick in the opposite direction to adjust the travel in the opposite direction.
7. The same may be done for all channels.
8. Press the *Scroll* button to access the Servo Reverse function.
9. To exit, press the *Scroll* and *Increase* buttons up simultaneously.

CHAPTER 8: Data Sheet

8

DATA SHEET

Model Number 1 _____

Model Name _____

CHANNELS	THRO (1)	AIL (2)	ELE (3)	RUDD (4)	GER (5)	FLP (6)
REVERSE SW	NORM • REV	NORM • REV	NORM • REV	NORM • REV	NORM • REV	NORM • REV
SUB TRIM						
TRAVEL ADJUST	+ %	+ %	+ %	+ %	+ %	+ %
	- %	- %	- %	- %	- %	- %
DIGITAL TRIM VALUE	- 40%	± %	± %	± %		

WING TYPE	NORM • FLAPERON • DELTA
V-TAIL	ON • OFF

			AIL (AI)	ELEV (EL)
DUAL RATE	POS 0	D/R	%	%
	POS 1	D/R	%	%

CHAPTER 8: Data Sheet

8

DATA SHEET

Model Number 2 _____

Model Name _____

CHANNELS	THRO (1)	AIL (2)	ELE (3)	RUDD (4)	GER (5)	FLP (6)
REVERSE SW	NORM • REV	NORM • REV	NORM • REV	NORM • REV	NORM • REV	NORM • REV
SUB TRIM						
TRAVEL ADJUST	+ %	+ %	+ %	+ %	+ %	+ %
	- %	- %	- %	- %	- %	- %
DIGITAL TRIM VALUE	- 40%	± %	± %	± %	/	

WING TYPE	NORM • FLAPERON • DELTA
V-TAIL	ON • OFF

			AIL (AI)	ELEV (EL)
DUAL RATE	POS 0	D/R	%	%
	POS 1	D/R	%	%

CHAPTER 8: Data Sheet

8

DATA SHEET

Model Number 3 _____

Model Name _____

CHANNELS	THRO (1)	AIL (2)	ELE (3)	RUDD (4)	GER (5)	FLP (6)
REVERSE SW	NORM • REV	NORM • REV	NORM • REV	NORM • REV	NORM • REV	NORM • REV
SUB TRIM						
TRAVEL ADJUST	+ %	+ %	+ %	+ %	+ %	+ %
	- %	- %	- %	- %	- %	- %
DIGITAL TRIM VALUE	- 40%	± %	± %	± %	/	

WING TYPE	NORM • FLAPERON • DELTA
V-TAIL	ON • OFF

			AIL (AI)	ELEV (EL)
DUAL RATE	POS 0	D/R	%	%
	POS 1	D/R	%	%

IMPORTANT INFORMATION

1

GENERAL NOTES

Radio controlled models are a great source of pleasure. Unfortunately, they can also pose a potential hazard if not maintained and operated properly. It is imperative that you install your radio control system correctly. Additionally, your level of piloting competency must be high enough to ensure that you are able to control your aircraft under all conditions. If you are a newcomer to radio controlled flying, please seek help from an experienced pilot or your local hobby shop.

Listed below are some safety “Dos and Don’ts” that must be followed by all pilots:

- Ensure that your batteries have been properly charged prior to initial flight.
- Keep track of the time that the system is turned on so that you will have an idea of how long you can safely operate your system.
- Perform a ground range check prior to the initial flight of the day. See the “Daily Flight Checks” section below for information on how to do so.
- Check all control surfaces prior to each takeoff.
- Use frequency flags.
- Do not fly your model near spectators, parking areas, or at any other area that could result in injury to people or damage of property.
- Do not fly during adverse weather conditions. Poor visibility can cause disorientation and loss of control of your aircraft. Strong winds can cause similar problems.
- Do not fly unless your frequency is clear.
Warning: Only one transmitter at a time can operate on a given frequency. If you turn on your transmitter while someone else is operating a model on your frequency, both pilots will lose control of their models. Only one person can use a given frequency at a time. It does not matter if it is AM, FM, or PCM — **only one frequency at a time.**
- Do not point the transmitter antenna directly toward the model. The radiation pattern from the tip of the antenna is inherently low.
- Do not take chances. If at any time during flight you observe any erratic or abnormal operation, land immediately and do not resume flight until the cause of the problem has been ascertained and corrected.

2

DAILY FLIGHT CHECKS

1. Check the battery voltage on both the transmitter and the receiver battery packs. Do not fly below 9.0 volts on the transmitter or below 4.7 volts on the receiver. To do so can cause a crash of your aircraft.

Note: When you check these batteries, ensure that you have the polarities correct on your expanded scale voltmeter.

2. Check all hardware (linkages, screws, nuts, bolts) prior to each day’s flight. Be sure that binding does not occur and that everything is properly secured.
3. Ensure that all surfaces are moving in the proper manner.
4. Perform a ground range check before each day’s flying session. The range check should be as follows:
 5. Do not extend the transmitter antenna at this time. Turn the transmitter on.
 6. Turn the model on.
 7. Slowly walk away from the model while moving the control surfaces. The aircraft should function properly at a distance of 75–100 feet.
5. Just prior to starting your aircraft, turn off your transmitter and then turn it back on. Do this each time you start your aircraft. If any critical switches are on without your knowledge, the transmitter alarm will warn you at this time.
6. Ensure that all trim levers are in the proper location.
7. Check to be sure that all servo pigtails and switch harness plugs are secured in the receiver. Also, make sure that the switch harness moves completely in both directions.

WARRANTY AND SERVICE INFORMATION

Important Note: Be sure to keep your original dated sales receipt in a safe place as you will be required to provide proof-of-purchase date for the equipment to be serviced under warranty.

3

WARRANTY COVERAGE

Your new JR Remote Control Radio System is warranted to the original purchaser against manufacturer defects in material and workmanship for one year from the date of purchase. During this period, Horizon Service Center will repair or replace, at our discretion and at no cost to the purchaser, any component that is found to be factory defective. This warranty is limited to the original purchaser of the unit and is not transferable.

This warranty does not apply to any unit which has been improperly installed, mishandled, abused, or

damaged in a crash, or to any unit which has been repaired or altered by any unauthorized agencies. Under no circumstances will the buyer be entitled to consequential or incidental damages. This limited warranty gives you specific legal rights; you also have other rights which may vary from state to state. As with all fine electronic equipment, do not subject your radio system to extreme temperatures, humidity or moisture. Do not leave it in direct sunlight for long periods of time.

4

REPAIR SERVICE INSTRUCTIONS

In the event that your JR radio needs service, please follow the instructions listed below:

1. Check all on/off switches to be sure they are off. This will speed the repair process of checking battery condition.
2. Return your system components only (transmitter, receiver, servos, etc). Do not return your system installed in a model aircraft.
3. Preferably, use the original carton/packaging (molded foam container), or equivalent, to ship your system. Do not use the system carton itself as a shipping carton. You should package the system carton within a sturdy shipping container using additional packing material to safeguard against damage during transit. Include complete name and address information inside the carton, as well as clearly writing it on the outer label/return address area.
4. Include detailed information explaining your operation of the system and problem(s) encountered. Provide an itemized list of equipment enclosed and identify any particular area/function which may better assist our technicians in addressing your concerns. Date your correspondence and be sure your complete name and address appear on this enclosure.

5. Include your name, mailing address, and a phone number where you can be reached during the business day.

6. **Warranty Repairs.** To receive warranty service, you must include your original dated sales receipt to verify your proof-of-purchase date. Providing that warranty conditions have been met, your radio will be repaired without charge.

7. **Normal Non-Warranty Repairs.** Should your repair cost exceed 50% of the retail purchase cost, you will be provided with an estimate advising you of your options.

Within your letter, advise us of the payment method you prefer to use. Horizon Service Center accepts VISA or MasterCard. Include your card number and expiration date. Horizon Service Center also accepts money orders.

Mail your system to:

Horizon Service Center
4105 Fieldstone Road
Champaign, IL 61822
Phone: (217) 355-9511
www.horizonhobby.com

FREQUENCY CHART

5

FREQUENCY CHART

72MHz requires no special license to operate.

50/53MHz requires the operator to have an FCC amateur radio license (Ham).

72MHz		72MHz		50MHz	
CH.NO.	FREQUENCY	CH.NO.	FREQUENCY	CH.NO.	FREQUENCY
15	72.090	36	72.510	00	50.800
16	72.110	37	72.530	01	50.820
17	72.130	38	72.550	02	50.840
18	72.150	39	72.570	03	50.860
19	72.170	40	72.590	04	50.880
20	72.190	41	72.610	05	50.900
21	72.210	42	72.630	06	50.920
22	72.230	43	72.650	07	50.940
23	72.250	44	72.670	08	50.960
24	72.270	45	72.690	09	50.980
25	72.290	46	72.710		
26	72.310	47	72.730		
27	72.330	48	72.750		
28	72.350	49	72.770		
29	72.370	50	72.790		
30	72.390	51	72.810		
31	72.410	52	72.830		
32	72.430	53	72.850		
33	72.450	54	72.870		
34	72.470	55	72.890		
35	72.490	56	72.910		
		57	72.930		
		58	72.950		
		59	72.970		
		60	72.990		

53MHz		
CH. NO.	FREQUENCY	FLAG COLOR
A1	53.100	Black/Brown
A2	53.200	Black/Red
A3	53.300	Black/Orange
A4	53.400	Black/Yellow
A5	53.500	Black/Green
A6	53.600	Black/Blue
A7	53.700	Black/Purple
A8	53.800	Black/Gray

***Channels 11-14 are not available**

NOTES



NOTES





DISTRIBUTED EXCLUSIVELY BY HORIZON HOBBY DISTRIBUTORS CHAMPAIGN, IL 61822
www.horizonhobby.com

© 1999 Horizon Hobby Distributors, Inc. All Rights Reserved.