

R-1



matrix graphic display

model memory

CM/PPM selectable

sophisticated A.B.S.
locking system available

programmable 8-point
throttle and brake curve

digital, fully programmable
with auto trim memory

timer gives record of last 99
best lap, average lap, etc.

independently adjustable speed
control, both turning and
braking

low current battery consumption—
batteries last approximately
10 hours

JR RACING

Quick Start

Congratulations on your purchase of the most advanced racing radio system available. We know you're anxious to get going with your new R-1, so we've provided this Quick Start section that allows you to quickly set-up your new

radio with just the basic settings to get you to the track quickly. When you've got time, we suggest that you read each section in this manual to better understand the advanced features of the R-1.

Step 1. Install 8 AA batteries (not included) in the transmitter. The battery door is located on the bottom of the transmitter. The negative (flat) end of the battery goes toward the spring.

Step 2. Press and hold the MODE LIST key while turning on the transmitter. Your screen should look like this:

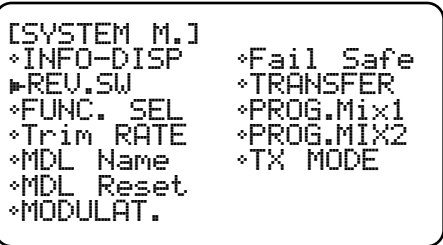

Press and hold the MODE LIST key while turning on the transmitter. Press the key a second time to access the reverse switch screen

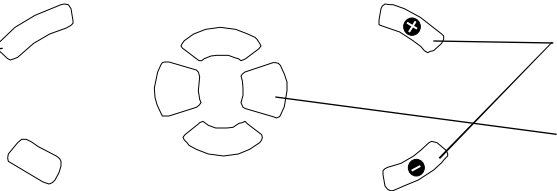

Press the + or - key to reverse the servo direction of the selected channel

Press the SEL key to select the desired channel

Step 3. SERVO REVERSE: Now press the MODE LIST key again. The screen should now look like this:

Press the SEL button to select the channel you wish to reverse, then press the + or - key to change that servo's direction.

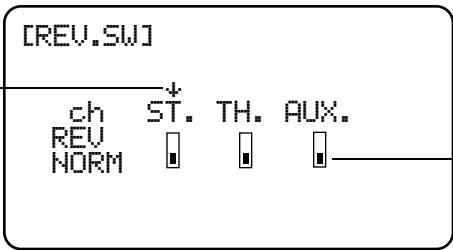

Indicates selected channel

Indicates REV or NORM is selected

Step 4. TRAVEL ADJUST: Turn off the transmitter, then turn it back on. Now press the MODE LIST key twice. Your screen should look like this:

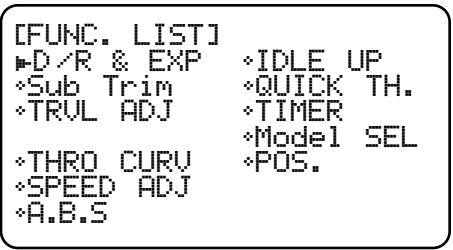

Press the MODE LIST key twice after the transmitter is turned on

Press the UP or DOWN key until the cursor aligns with the TRVL ADJ, then press the MODE LIST key

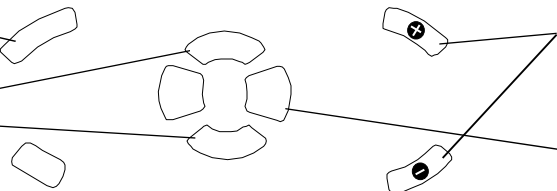

Use the + or - key to adjust the travel

Press the SEL key to select the desired channel

Step 5. Press the UP or DOWN key until the cursor aligns with TRVL ADJ. (travel adjust).

Step 6. Now press the MODE LIIST key. Your screen should look like this:

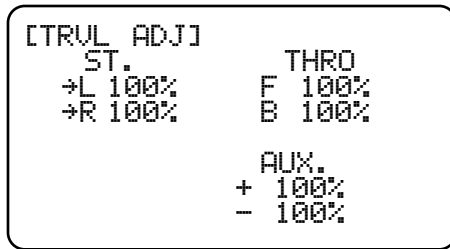

Press the SEL key to select which channel you wish to adjust. Press the + or - key to adjust the value. **Note:** To adjust the travel in one direction only, move the selected channel's input (e.g., steering wheel) in the direction you choose to change (right turn, left turn).

That's it — you're ready to go!

Index

Control Identification	4	Trim Rate	16
Display Switch	4	Model Name	17
Transmitter Module	5	Data Reset	18
Installing the Batteries	6	Modulation	19
D.S.C. (Direct Servo Control)	6	Fail-Safe	20
Receiver Hook-Up	7	Transfer	22
The Key Pad	7	Programmable Mix 1 and 2	24
General Information About Programming the R-1	8	Tx Mode	25
Beeping Confirmation	8	Function Mode Functions	
Two-Speed Scrolling	8	Dual Rate/Exponential	26
Contrast Adjustment of the Display	8	Sub-Trim	27
Digital Trims	8	Travel Adjust	28
Battery Alarm	8	Throttle Hold	29
Warning Alarm	8	Throttle Curve	30
Back-Up Error	8	Speed Adjust	32
Normal Display	9	Advanced Braking System (A.B.S.)	33
System Mode	10	Idle Up	35
Function Mode	11	Quick Throttle	36
System Mode Functions		Timer	37
Reverse Switch	14	Model Select	40
Function Select	15	Position	41
		Data Sheet	42
		Warranty Information	43

Control Identification



- 1 Antenna
- 2 RF Transmission Indicator*
- 3 Power Switch
- 4 Display Indicator
- 5 Charge Jack
- 6 D.S.C. Jack
- 7 Display Switch
- 8 Timer Button
- 9 Drive Mode Switch
- 10 Grip Trimmer A
- 11 Grip Trimmer B
- 12 Throttle Digital Trimmer
- 13 Steering Digital Trimmer
- 14 Auxiliary 3 Channel (Ch3)
- 15 Idle Up Switch
- 16 Steering Tension Adjustment**
- 17 Dot Matrix Graphic Display
- 18 Steering Wheel (Ch1)
- 19 Throttle/Brake Lever (Ch2)
- 20 Key Pad

*Note: The RF Transmission Indicator will not be on when the display switch is activated. Also it will not be illuminated when there is not a module installed in the transmitter.

**Note: Steering Tension is adjustable via the Phillips head screw recessed next to the idle up switch. Screwing clockwise increases the steering tension.

Display Switch

The display switch allows the input of data without transmitting a signal. This is useful for making adjustments while not affecting others that may be on the same frequency. With

the power switch off, turning on the display switch will activate the display and all programming functions can be accessed. This also uses about 2/3 less power; if you plan on working with the programming for a while, using the display switch will save batteries.

Note: The antenna included with the R-1 is the screw-in type (part #JRPA160). When in use, be sure the antenna is screwed in firmly, and the antenna is extended fully.

Transmitter Module

The R-1 features a replaceable module which allows for the changing of frequencies or bands. To remove the module, press the tabs located on the module inward while pulling the module out. Replacement crystals and modules are available separately, allowing frequency changes to be made.



FREQUENCY CHART

FREQUENCY (MHZ)	CHANNEL	FREQUENCY (MHZ)	CHANNEL	FREQUENCY (MHZ)	CHANNEL
26.995.....	1	75.530.....	67	75.770.....	79
27.045.....	2	75.550.....	68	75.790.....	80
27.095.....	3	75.570.....	69	75.810.....	81
27.145.....	4	75.590.....	70	75.830.....	82
27.195.....	5	75.610.....	71	75.850.....	83
27.255.....	6	75.630.....	72	75.870.....	84
75.410.....	61	75.650.....	73	75.890.....	85
75.430.....	62	75.670.....	74	75.910.....	86
75.450.....	63	75.690.....	75	75.930.....	87
75.470.....	64	75.710.....	76	75.950.....	88
75.490.....	65	75.730.....	77	75.970.....	89
75.510.....	66	75.750.....	78	75.990.....	90

Installing the Batteries

The R-1 transmitter requires 8 AA batteries (not included). To install the batteries, remove the battery door on the bottom of the transmitter and install the batteries such that the coil spring in the battery holder contacts the negative (flat) side of the battery. Alkalines will provide power for approximately 7 hours of use. An optional rechargeable Ni-Cad battery pack is also available separately (part #JRPB9280).



CAUTION! When charging Ni-Cads in the R-1, note that the charge jack is center pin negative (see diagram below). Be sure to use a JR charger or verify that the charger you're using is center pin negative before charging. Typical slow charge rates are 50mA for 12 hours, while most Sanyo brand AAs can be charged at up to 1 amp. Be sure to use a reliable peak charger if you're fast charging your transmitter and remember the center pin is negative!

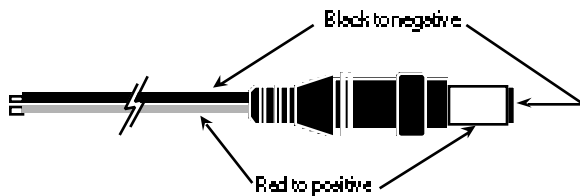

D.S.C. (Direct Servo Control)

The R-1 features a D.S.C. function that allows the operation of the servos/speed controller without transmitting a signal. This allows testing and adjustment of the radio/speed controller without affecting others that may be on the same frequency.



Note: An optional D.S.C. cord (part # JRPA134) is required to operate the D.S.C. function.

To operate, plug the male end of the D.S.C. cord into the D.S.C. jack located under the panel on the front upper left of the transmitter. The other radio connector end of the D.S.C. cord is inserted in the battery slot in the receiver. **Note:** If using a gas car, a Y harness will need to be used so the battery and D.S.C. cord can both be installed in the battery slot on the receiver (part #JRPA133).

Now turn on the speed controller switch (electric) or the receiver's power switch (gas) while leaving the transmitter's power switch turned off. If nothing happens, you may need to charge the batteries in your car.

The servos/speed controller should work normally while no transmission is taking place.

Note: Only JR brand receivers are compatible with the R-1's D.S.C. function. After-market receivers will not work with the D.S.C. function.

Receiver Hook-Up

Electric Car Set-Up

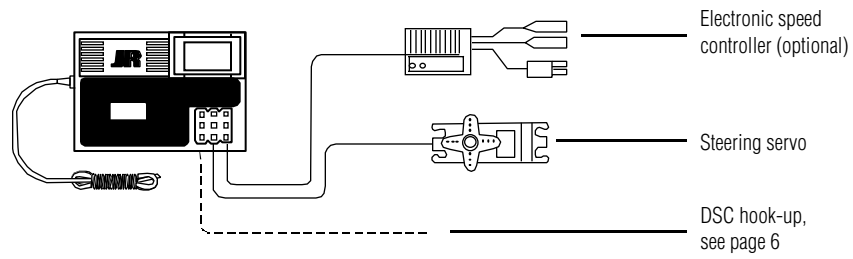

Gas Car Set-Up

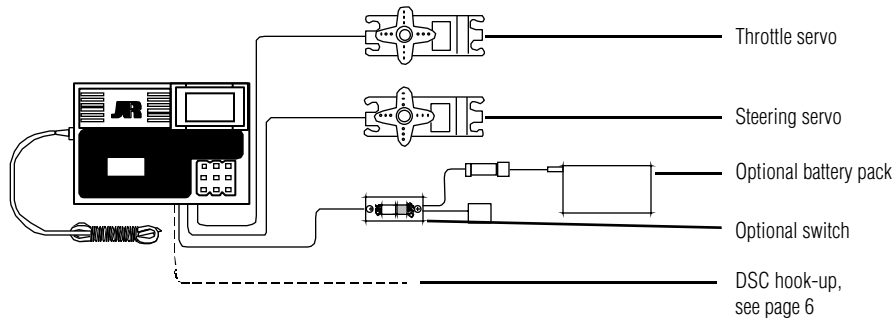

The Key Pad

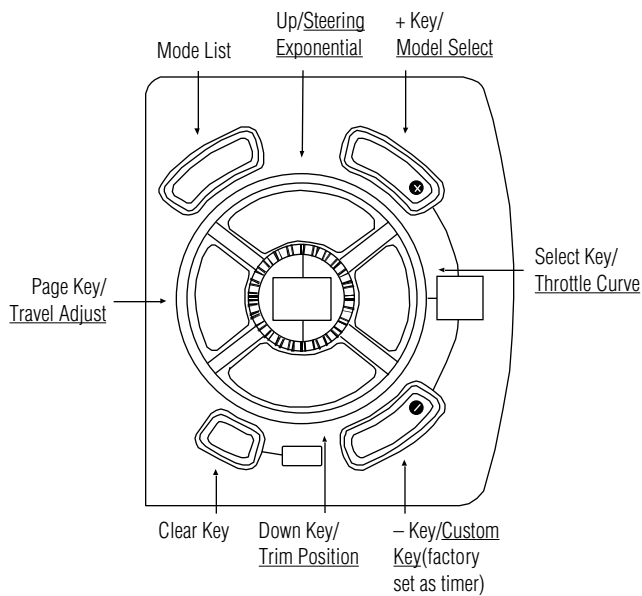

Note: The underlined portion of the key is its function when using Direct Mode.

General Information About Programming the R-1

Beeping Confirmation

A beeping sound will be heard when inputting, verifying the input is valid.

Two-Speed Scrolling

All the keys (except the clear key) feature two-speed scrolling. Holding the key down for more than 3 seconds will automatically switch from low to high speed scrolling, which is helpful when making large value changes in programming.

Contrast Adjustment of the Display

The contrast of the display can be adjusted by doing the following:

1. Turn on the power switch
2. Hold down the SEL key
3. Now, while holding down the SEL key, press the + key to darken the display or press the - key to make the display lighter.

Digital Trims

There are five digital trims on the R-1 (see page 4 for locations). Each digital trim is adjusted by pressing the trim button in one of the two available directions.

Note: A beep will be heard with each step of trim adjustment. When passing the center, a different sounding beep and a hesitation will occur, indicating the center position. Also when the end of the trim is reached, a different sounding (pitch) beep is heard. Also note that the tone of the beep changes from one extreme side of the trim to the other; this change in tone allows you to know approximately where the trim is set just by the relative tone of the beep when a digital trimmer is adjusted.

Digital trim positions are automatically stored in memory when switching from one model to the next.

The function of each of the five digital trims can be programmed to one of the seven following functions: steering trim, steering dual rate, throttle trim, panic brake, channel 3, A.B.S. swing, A.B.S. point.

Battery Alarm

When the battery voltage drops below 9.0 volts, BATT will flash on the display and an alarm will sound five times. When BATT appears on the screen, many of the programming functions are disabled. Replace (AA) or recharge (Ni-Cads) the batteries.

Warning Alarm

If the Drive Mode or Idle Up switch is in a different position then when you last turned the radio off, an alarm will sound warning of this condition and the display will indicate which switch is at fault. Switching the offending switch to the proper position will shut off the alarm and normal operation is resumed. If this alarm function is not desired, it can be turned off in Transmitter Mode function (page 25).

Back-Up Error

A built-in five year Lithium battery functions as battery back-up should the main battery fail (for example, if the transmitter was left on). This back-up battery will maintain all programmed information. If 1 BACK UP ERROR appears on the screen accompanied by an alarm sound, the Lithium battery needs to be replaced and/or the unit needs repair.

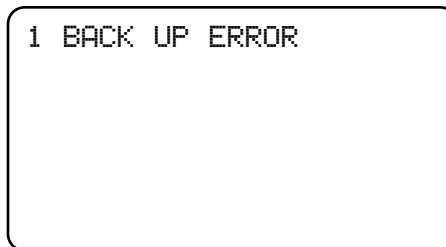

Return the transmitter to the following address for lithium battery replacement and repair:

Horizon Service Center

4105 Fieldstone Road
Champaign, IL 61821
217/355-9511

Fortunately, the Lithium battery conservatively lasts a good five years, and by then it's a good idea to have your radio returned and checked out by our service technicians.

Steering Tension

Steering Tension is adjustable via the recessed screw just behind the idle up switch (see page 4 and 16). Turning the screw clockwise increases the steering tension.

Normal Display

When the power switch is turned on, the normal display appears.

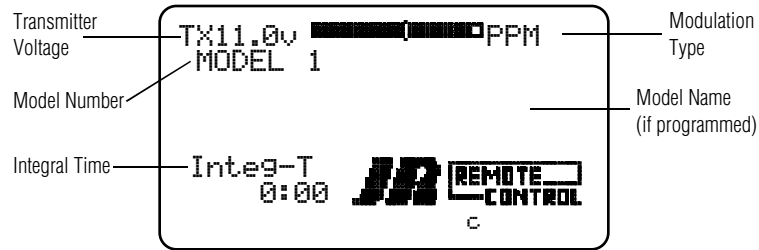

Note: Trim positions will appear here if D.T. display is turned on in Tx Mode; ABS will appear here if it is turned on.

When the normal display is shown, pressing the MODE LIST key will access the Direct Mode. Then, by pressing the UP or DOWN key, the menus in function list are accessible. Each time the UP or DOWN key is pressed, it advances to the next programming feature. Depending on what mode you're in, pressing the MODE LIST key several times will bring up the function list that displays all the available menus in function mode on a single screen (see page 11). These can be scrolled through using the UP or DOWN key to move the cursor and accessed by pressing the MODE LIST key.

System Mode

Also called System Set-Up Mode, this mode contains programming features that are usually only adjusted once during the initial set-up of a particular car, and once set, they're seldom, if ever, changed at the track. System Mode programming features include servo reversing, model name, modulation type, data transfer, etc.

To enter the System Mode, press and hold the MODE LIST key, then turn on the transmitter. Press the MODELIST key again to enter the select menu

Use the UP key to scroll up through the menu

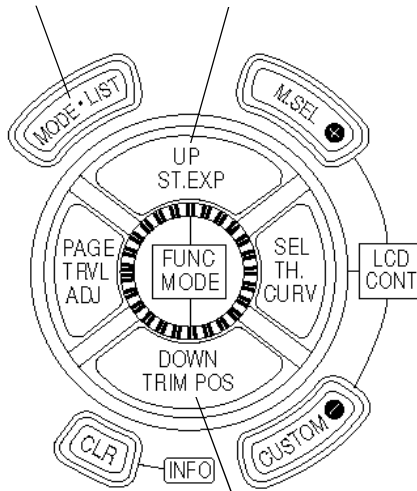

Use the DOWN key to scroll down through the menu

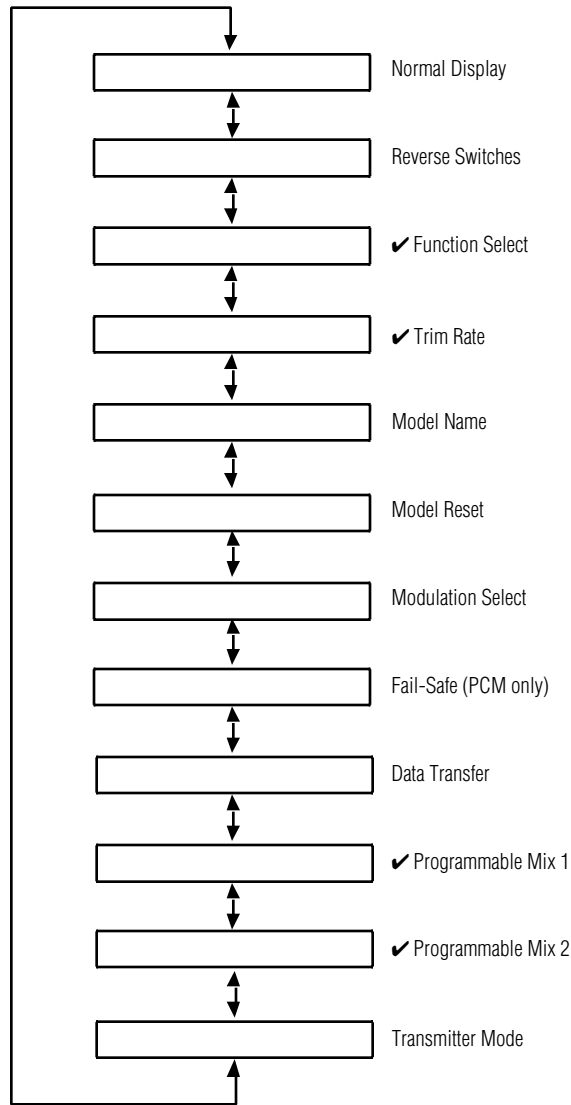

Note: When in a function, press the UP and DOWN keys simultaneously to return to Normal display.

Note: Functions marked with a ✓ do not appear on the screen when the transmitter is in Beginner Mode.

Function Mode

The R-1's programming is laid out in two paths or modes that are accessed in different ways. Function Mode contains the most commonly used programming features that you'll likely be changing at the track in your car. Features such as dual rate, expo A.B.S. brakes, lap timer, etc., are found in Function Mode.

To enter the Function Mode, press the MODE LIST key twice after turning on the transmitter. Press the MODE LIST key again to enter the selected menu

Use the UP key to scroll up through the menu

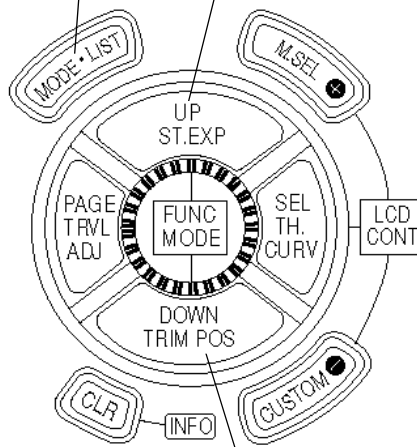

Use the DOWN key to scroll down through the menu

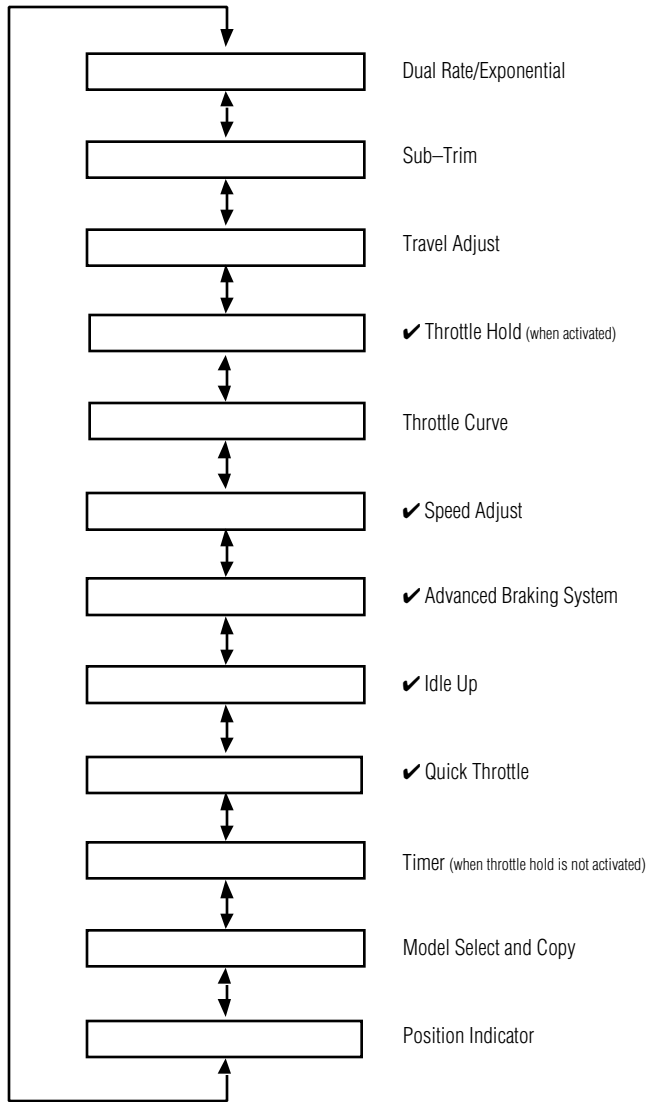

Note: When in a function, press the UP and DOWN keys simultaneously to return to Normal display.

Note: Functions marked with a ✓ do not appear on the screen when the transmitter is in Beginner Mode.

Accessing System Mode

To access system mode, depress and hold the MODE LIST key while turning on the transmitter. The System Mode menu will appear. Select the desired function by moving the cursor with the up or down key, then press the MODE LIST key to enter the selected function.

```
[SYSTEM M.]
*INFO-DISP
*REV.SW
*FUNC. SEL
*Trim RATE
*MDL Name
*MDL Reset
*MODULAT.
*Fail Safe
*TRANSFER
*PROG.Mix1
*PROG.MIX2
*TX MODE
```

Pressing the MODE LIST key while in the selected function will return to the System Mode list, or pressing the UP and DOWN keys simultaneously will return the display to the Normal Mode.

Note: The servos will not operate in System Mode. Select the normal display or the Function Mode to operate the servos.

System Mode List

When entering System Mode, the System Mode list automatically comes up. This list provides a complete listing of all the available programming features in this mode. When this list is displayed, pressing the UP or DOWN keys will move the cursor to the desired programming feature. Access the desired feature by pressing the MODE LIST key.

Once in a function, return to the normal display by either pressing the MODELIST key and then the CLR key, or press the UP and DOWN keys simultaneously—both methods will bring you back to the normal display.

Beginner/Expert Mode

The R-1 allows the racer to select between an expert mode (all the advanced programming features are accessible) or beginner mode (advanced features such as programmable mix, trim rate, etc.) do not come up in the menu list, making programming less confusing for beginners. The Beginner/Expert Mode is selected in Tx Mode (page 25). The programming features which are deleted in the beginner mode are marked with a ✓ on the previous page.

Accessing Function Mode

To access the Function Mode, first turn on the transmitter. The normal display will appear. Now press the MODE LIST key; DIRECT MODE will appear on the screen.

```
DIRECT MODE
```

Pressing the Mode List key will display the function list or pressing any of the other keys will directly access the function listed in orange on that key (see Direct Mode Access section below).

Function Mode List

To display a complete listing of all the available programming features in Function Mode when the Normal display is shown, press the MODE LIST key two times. The Function List screen will appear:

```
[FUNC. LIST]
*D/R & EXP
*Sub Trim
*TRVL ADJ
*THRO CURV
*SPEED ADJ
*A.B.S
*IDLE UP
*QUICK TH.
*TIMER
*Model SEL
*POS.
```

Press the UP and DOWN keys to move the cursor to the desired programming feature. Access the desired feature by pressing the MODE LIST key

Once in a function, return to the Normal display by either pressing the MODE LIST key and then the CLR key, or press the UP and DOWN keys simultaneously—both methods will bring you back to the Normal display.

Direct Mode Access

Direct Mode Access allows the direct access of the most commonly used programming features, which include steering expo, throttle curve, trim position, travel adjust, model select, normal display and a custom key that's factory programmed to access the timer.

Note: Direct Mode cannot be accessed in System Mode.

To access Direct Mode from the normal display, press the MODE LIST key once.

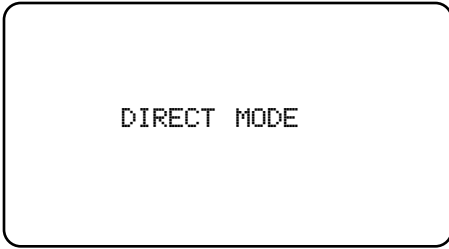

Now press the key that you wish to access. **Note:** The Direct Mode function is written in orange on the key pad.

Note: The Timer function is assigned at the factory to the custom – key. See page 15 to change the custom key to direct access the program of your choice.

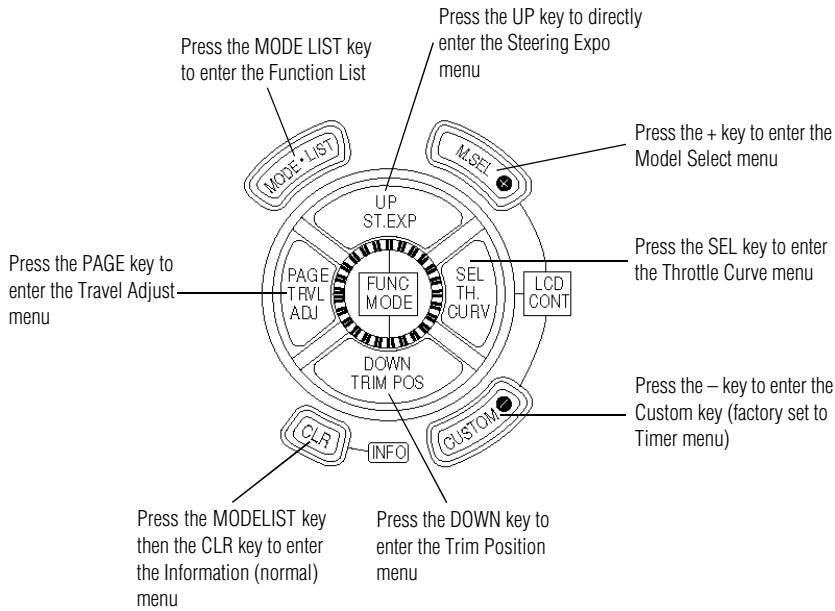

NOTE:

The functions on the following pages are accessed via the System Mode. To enter System Mode, press and hold the MODE LIST key while turning on the transmitter.

Reverse Switch

Reverse switch is used to select the correct direction of the servo's travel.

In System Mode, access the Reverse Switch function by moving the cursor to REV.SW and pressing the MODE LIST key.

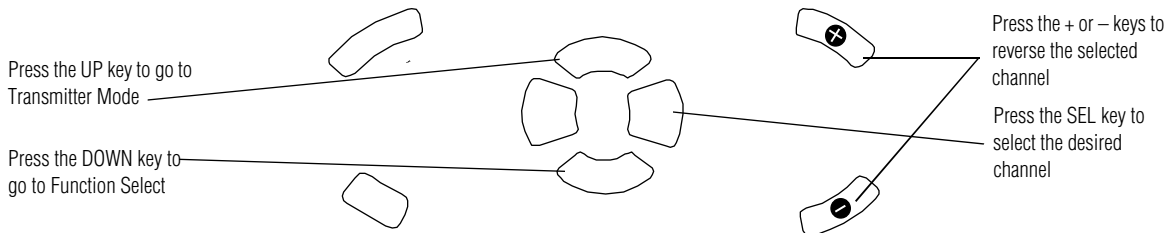
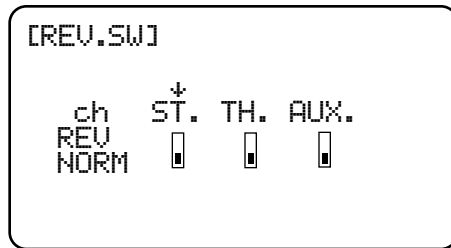

Function Select

The function select feature allows you to program the five available digital trims, the two available switches and the thumb-operated button to one of the following functions:

Note: Each function can only be programmed to one switch or digital trimmer. If the function you wish to select is already programmed to another switch or trimmer, it must first be removed from that switch or trimmer before it can be reprogrammed to another.

In System Mode, access the Function Select function by moving the cursor to FUNC. SEL and pressing the MODE LIST key.

Note: The trimmer switch or button flashes when selected

```
[Func. SEL]
D.T. ST.TRIM
TH.TRIM [ + ] AUX=3ch
DR.MODE [ + ] IDLE UP
Timer
TH.BRKE
ST.D/R
```

Press the PAGE key to access the Direct Mode custom key

Press the DOWN key to go to Trim Rate

Press the CLR key to inhibit the selected trimmer, switch or button

Press the UP key to go to Reverse Switch

Press the + or - keys to change the selected trimmer, switch or button to the desired function

Press the SEL key to select the desired trimmer, switch or button

Switches :

- Drive mode
- Idle up
- Inhibit (turned off)

Buttons:

- Timer
- Throttle hold
- Inhibit

Digital Trims:

- Throttle trim (coast brake)
- Steering trim
- Throttle brake (panic brake)
- Steering rate
- ABS swing (see ABS braking page 33)
- ABS point (see ABS braking page 33)
- Aux. 3 channel Inhibit (turned off)

Press the PAGE key to access the Function Select Direct Mode, which allows you to program a direct access function on the CLR key. Use the + or - keys to select the desired function.

```
[FUNC. SEL]
DIRECT MODE

[CUSTOM(-)] key
TIMER Func.
```

Direct access function selected

Trim Rate

The trim rate function allows the trim authority (the amount of trim available) to be adjusted. This is especially useful to adjust the proper brake range available with the throttle trim and throttle brake. Aux. 3 travel rate is also adjustable in this function.

In System Mode, access the Trim Rate function by moving the cursor to Trim RATE and pressing the MODE LIST key.

Note: The Aux 3 channel can be assigned to any of the digital trims (see page 15). The Aux 3 channel rate is adjustable from 0–100% and gives proportional function when a value of 0–100% is selected. Above 100%, five step modes are available (1,2,3,4,5). When the step mode is accessed (by pressing the + key), each time the digital trimer is pressed, the Aux 3 servo steps to the next position and is non-proportional.

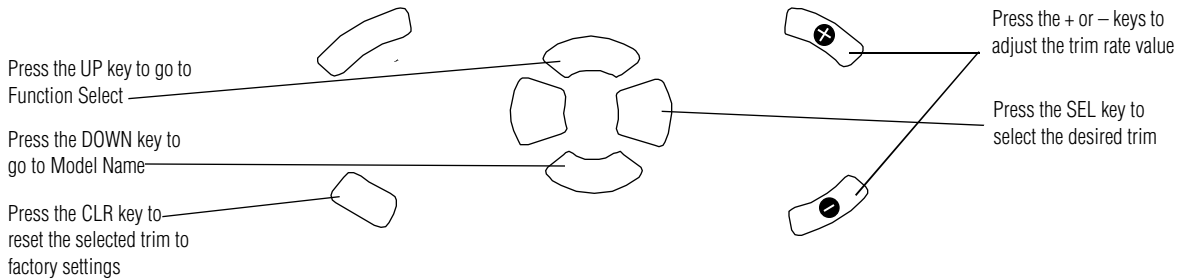
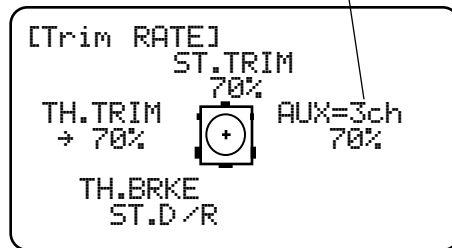

Model Name

The model name function allows the storing of a model's name using up to eight characters. This is important for future identifications purposes in selecting a model. Some racers like to store the channel number as well as a reminder; for example, Vector 65.

In System Mode, access the Model Name function by moving the cursor to MDL Name and pressing the MODE LIST key.

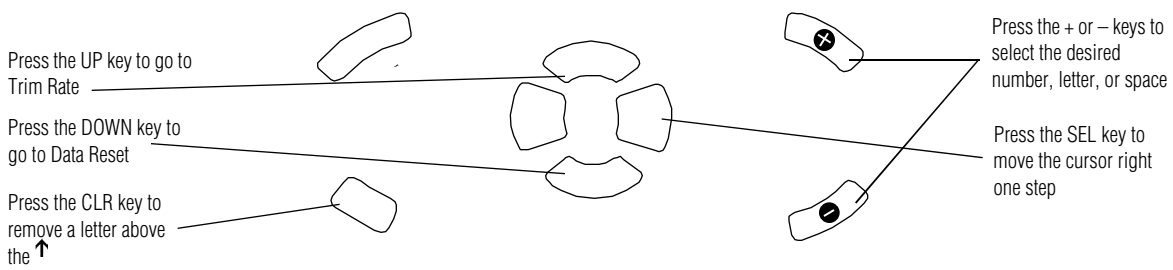
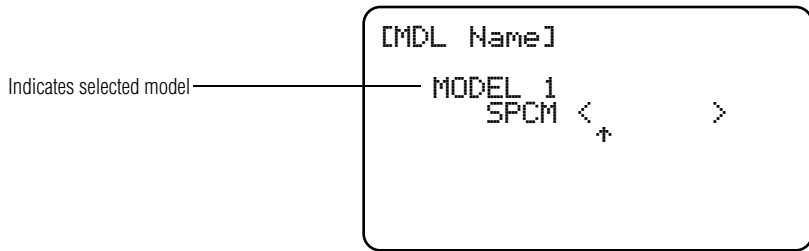

Data Reset

The data reset function resets all the memory (in the selected model only) back to the factory default settings.

In System Mode, access the Data Reset function by moving the cursor to MDL Reset and pressing the MODE LIST key.

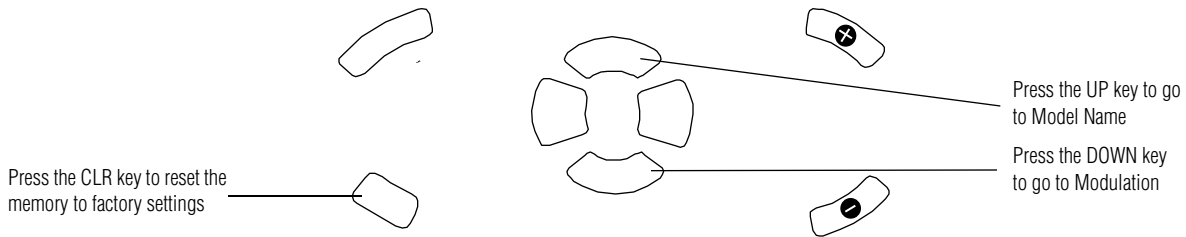
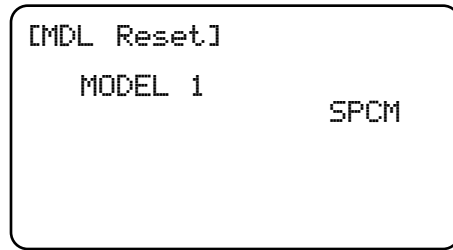

Modulation

The R-1 can transmit in three types of modulation — PPM (FM), ZPCM and SPCM.

PPM (also referred to as FM) modulation should be selected when using after-market receivers and when using JR FM receivers, such as the R200 or the 223.

ZPCM is Pulse Code Modulation with a 512 step resolution and is used with JR's 233 receiver.

SPCM is Pulse Code Modulation with a 1024 step resolution and is activated when using the JR 330 PCM receiver.

Be sure to select the correct modulation type for the receiver being used.

In System Mode, access the Modulation function by moving the cursor to MODULAT. and pressing the MODE LIST key.

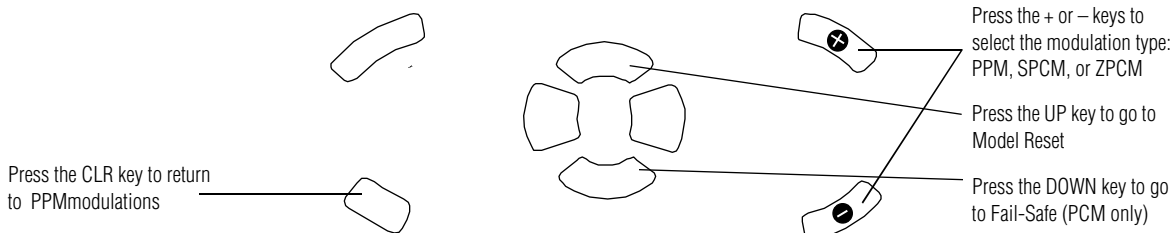
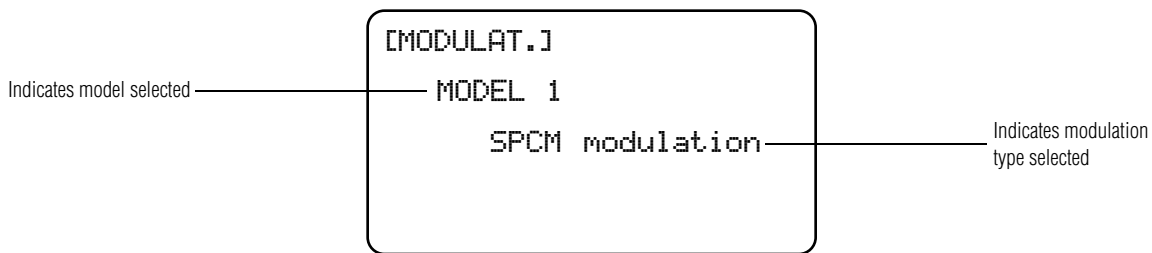

Fail-Safe (only available when PCM is activated)

In PCM modulation, a fail-safe function is available that will cause the servos and speed controller to assume either a preset fail-safe position (normally full brakes and straight steering) or to hold the last position when radio interference is encountered.

Using the SEL key, you can set each of the three channels to the fail-safe or the hold function.

In System Mode, access the Fail-Safe function by moving the cursor to Fail Safe and pressing the MODE LIST key.

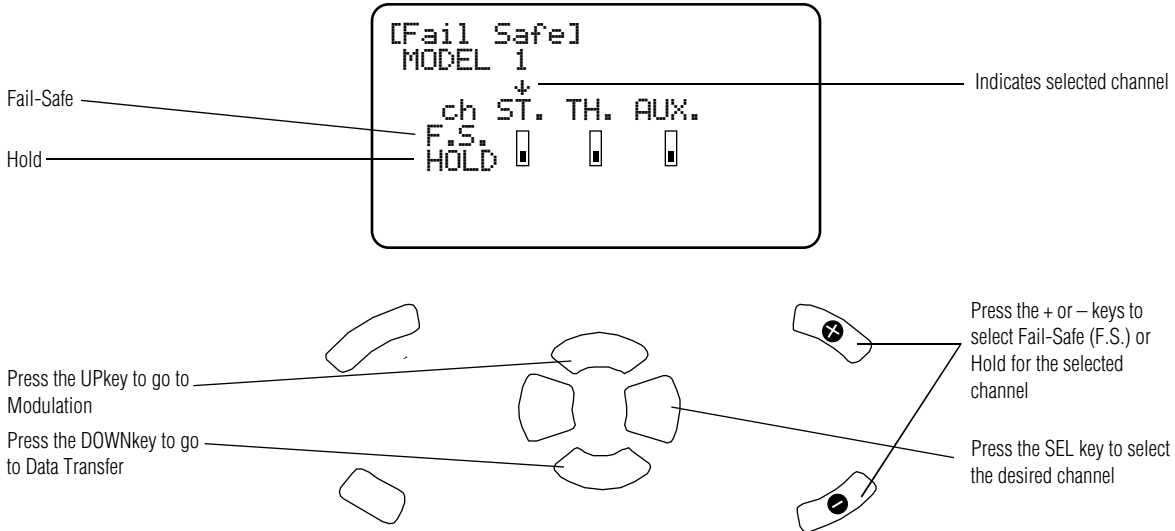

Storing Fail-Safe

SPCM Only

Indicates stored fail-safe position

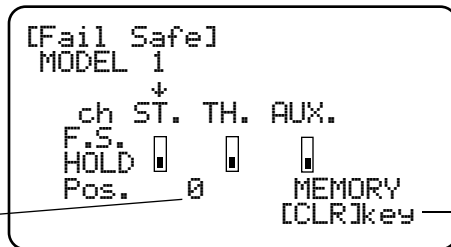

[CLR] key only appears when one or more channels are selected to F.S.

ZPCM Only

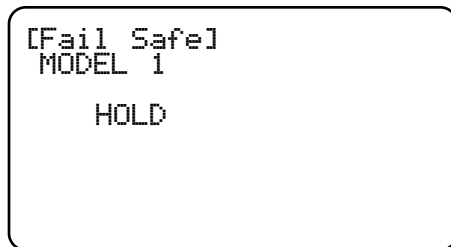

SPCM Only

Select the desired channel you wish to use with the fail-safe feature by moving the arrow above that channel using the SEL key. Use the + or - key to select F.S. or HOLD. Now

move the channel's stick or wheel for which you selected fail-safe in the position of the desired fail-safe.

Example: Full brakes and straight steering. Press the CLR key while holding the desired position with the throttle and steering. A beep will indicate the position is stored and the stored value will be displayed on the bottom center of the screen.

Note: When using ZPCM, you can choose the amount of time delay between the point of interference to the time fail-safe is activated. This delay can be set at 1/4, 1/2 or 1 second by pressing the + or -

key. Press the CLR key to store the desired fail-safe positions.

To check that fail-safe is working correctly, turn off the transmitter, thus eliminating the signal. The servos/speed controller should go to the desired fail-safe position.

Transfer

The R-1 allows the memory of a model to be transferred from one R-1 to another. A JR trainer cord (part #JRPA130) is needed to complete the transfer.

With the power off, press and hold the MODE LIST key while plugging the trainer cord in the DSC jack. Do this with both transmitters. Select the transfer screen on both R-1s.

In System Mode, access the Transfer function by moving the cursor to TRANSFER and pressing the MODE LIST key.

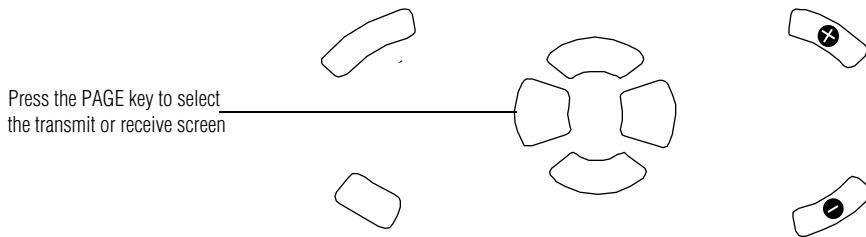
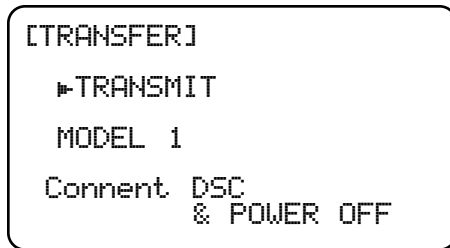

The transmitter from which you wish to transmit data should look like this:

```
[TRANSFER]
  ▶TRANSMIT
    Start=[CLR]
  MODEL 1
                                     0%
  Receiver
    stand-by ?
```

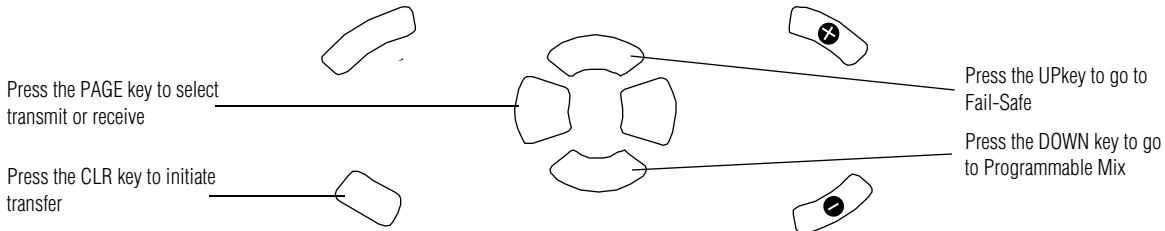

The transmitter that you're transmitting to (receiving) should look like this:

```
[TRANSFER]
                                     MODEL 1
  ▶RECEIVE
    Start=[CLR]
  MODEL 2
                                     0%
  SEL MODEL
    Push [+][I]-]
```

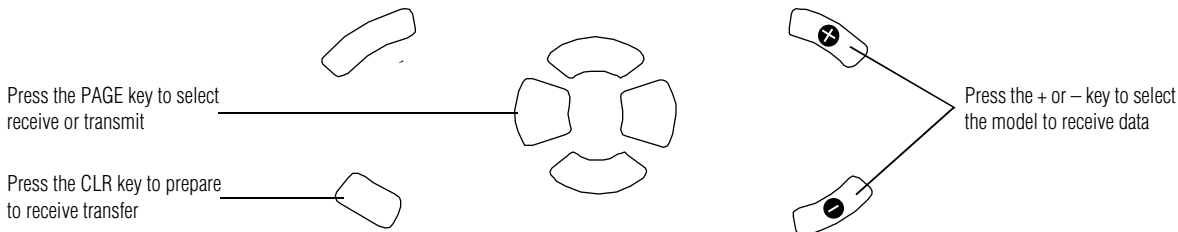

Now press the PAGE key to choose "transmit" on the transmitter you wish to transfer data from and "receive" on the transmitter that you wish to transmit to. On the receiving transmitter, press the + or - key to select the model memory that you wish to store the information in. Now press the CLR key on the receiving transmitter and "standby" will appear. Press the CLR key on the transmit transmitter. "End OK" will appear if a successful transfer has taken place.

```
[TRANSFER]
                                     MODEL 1
  ▶RECEIVE
  MODEL 2
                                     0%
  Stand-by
```

An Error message means the data was not received properly, and you need to try again using the above procedure.

Note: Be sure that "standby" appears on the receiving transmitter first before trying to send the information from the transmit transmitter.

Programmable Mix 1 and 2

The R-1 offers two programmable mixes that can be used to mix any two channels together. The mixing value can be adjusted independently in either direction, plus the switch can be selected to turn on/off the mixing. Both mixes work identically.

In System Mode, access Programmable Mixing by moving the cursor to PROG.MIX and pressing the MODE LIST key.

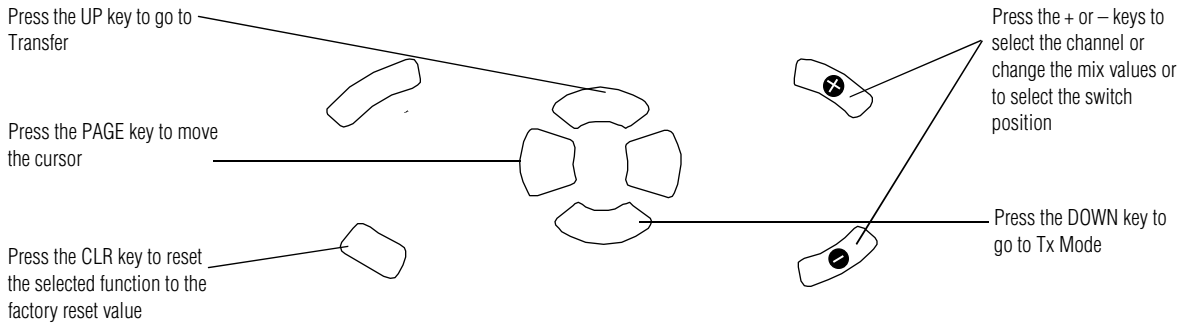
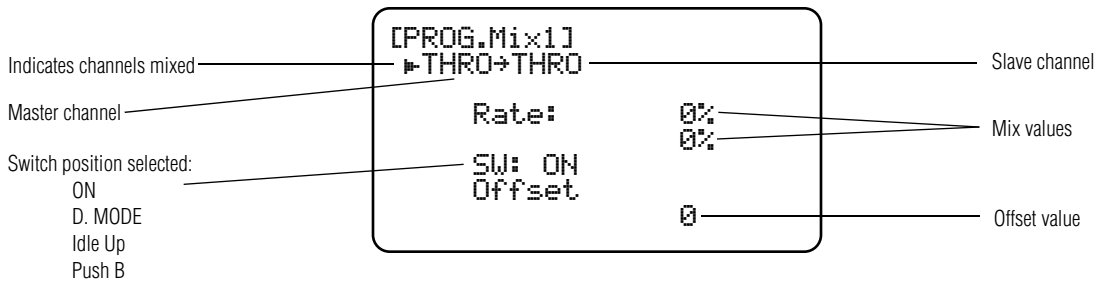

Tx Mode

The Tx Mode allows the setting of five different transmitter parameters—Mode, Buzz Tone, AUX 3 Channel, Warning, and D. T. Display.

In System Mode, access the Tx Mode function by moving the cursor to TX MODE and pressing the MODE LIST key.

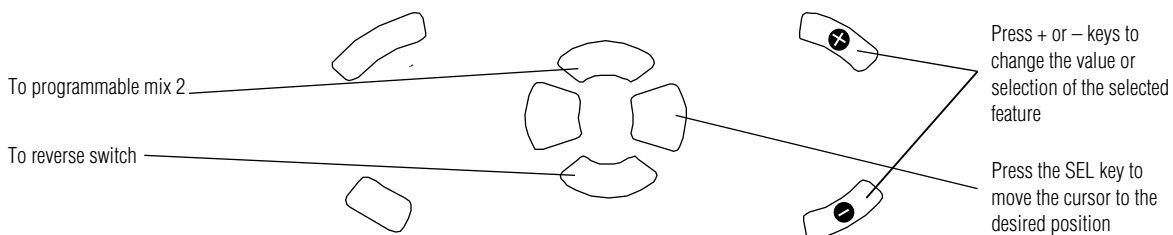
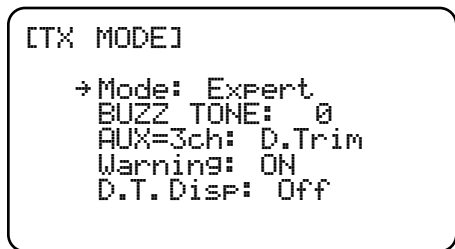

Mode

Mode allows the selection of either beginner or expert mode. In beginner mode, several of the more sophisticated functions, such as throttle hold, speed adjust, quick throttle, A.B.S. braking, quick throttle, idle up, function select, trim rate, and programmable mixing, are omitted, making it easier for beginners to program their radio.

In expert mode, all functions appear and are accessible on the Mode List screens.

Buzz Tone

Selecting buzz tone allows you to vary the pitch of the buzzer. 20 levels are available, and 0 is the factory default setting.

Aux.3 Channel

The Aux.3 channel can be programmed to any available (not assigned to anything else) digital trim or switch. When

Aux.3 is inhibited, the third channel's output is fixed at neutral, allowing channel 3 to be used as a slave with programmable mixing. This is useful for dual steering servos or dual throttles.

Warning

The warning switch can be turned on or off. With the warning switch in the on position, if the transmitter is turned off and the drive mode or idle up switch have been changed since the transmitter was last turned off, an alarm will sound and the screen will display the switch at fault. Turn the switch to the opposite position to stop the alarm.

D.T. Display

The Digital Trim Display can be turned on or off. In the on position, a graph is displayed on the info screen, visually showing the trim positions.

NOTE:

The functions on the following pages are accessed via the Function Mode. To enter Function Mode, turn on the transmitter, then press the MODE LIST key two times.

Dual Rate/Exponential

Two steering rates and exponential rates can be programmed and selected with the drive mode switch located at the bottom left side of the wheel. The amount of steering rate is adjustable from 0–100%. Exponential is also adjustable from 0 (linear) –100% in each switch position.

Dual Rate affects the total steering servo throw (both sides, right and left) simultaneously, so reducing the dual rate value makes the car less sensitive (twitchy) around neutral and also reduces the maximum amount of steering available.

Exponential allows you to tailor the response rate of the steering control around neutral without affecting maximum steering. Normally expo is used to settle down a car that's twitchy around center without giving up maximum steering response. The R-1 allows both a positive (normal) and negative (increases sensitivity at neutral) exponential value.

In Function Mode, access the Dual Rate/Exponential function by moving the cursor to D/R & EXP and pressing the MODE LIST key.

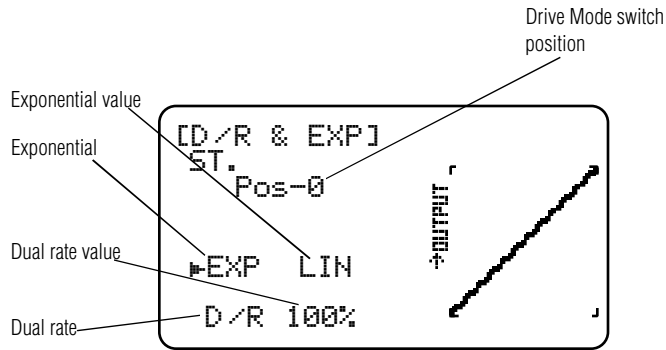

Press the MODE LIST key to return to Direct Mode

Press the DOWN key to go to Sub-Trm

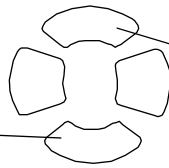

Press the + or - key to adjust the expo value

Press the UP key to go to Position Indicator



Note: Adjust the digital trim located on the grip to adjust the dual rate value.

Adjusting Dual Rates

Dual rate values are changed by using the digital trim that is pre-programmed at the factory on the lower grip digital trim button (grip dial B). Be sure to move the Drive Mode switch in the desired position before adjusting the dual rate (position 0 or 1).

Note: If the steering dual rate is not programmed to a digital trimmer, use the PAGE key to move the cursor to the D/R position and adjust the values with the + or - keys.

Note: If only one dual rate is desired, program both switch positions to the same value.

To adjust expo, use the PAGE key to move the cursor to the expo and press the + or - key. Don't forget to move the drive switch in the desired position.

Sub-Trim

Sub-trim allows you to electronically adjust the centering of your servos. Sub-trim is available for all three channels and is adjustable from 0–125% (+ or - 30% of servo travel).

In Function Mode, access the Sub-Trim function by moving the cursor to Sub Trim and pressing the MODE LIST key.

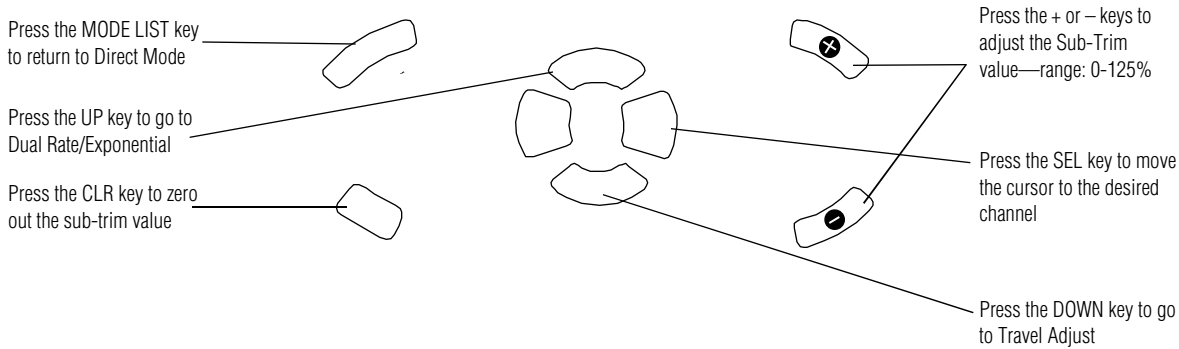
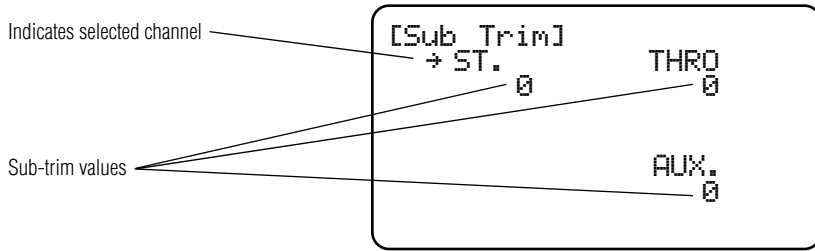

Note: Do not use excessive sub-trim as it's possible to over-run the servo's travel.

Note: Sub-trim changes both the center and the endpoint servo positions (right and left). You may want to recheck your endpoint positions if you adjust the sub-trim.

Travel Adjust

Travel adjust, also referred to as endpoint adjust or travel volume, allows the precise maximum servo throw in either direction to be independently adjusted. The travel adjust range is from 0–150% (0 to 60 degrees servo travel). This is used to set the maximum right/left steering and high full

brake positions independently. Remember, dual rate and brake trimmers work in unison with travel adjust.

In Function Mode, access the Travel Adjust function by moving the cursor to TRVL ADJ and pressing the MODE LIST key.

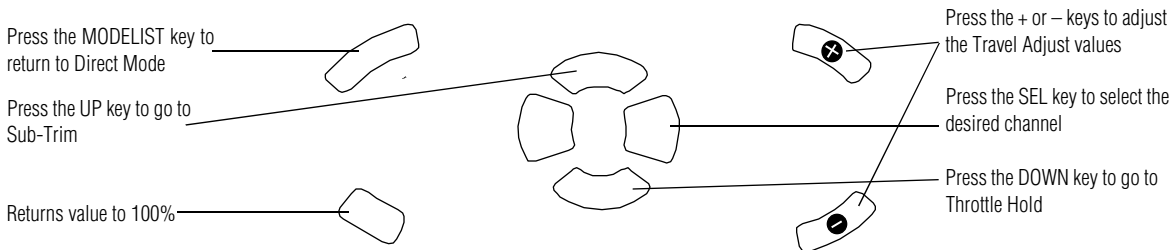
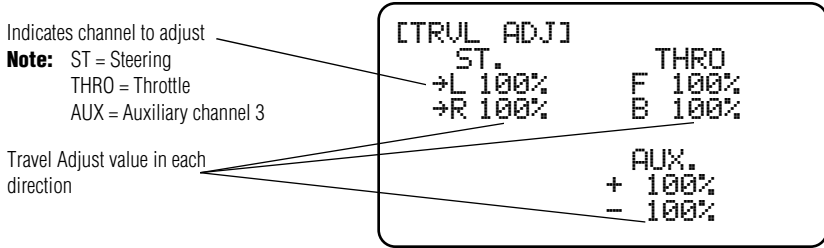

Note: Steering Travel Adjust (ST)—To independently adjust the left (L) or right (R) travel adjustment, turn the wheel in the direction you wish to adjust and the opposite cursors will be removed.

Note: Throttle Travel Adjust (THRO)—To independently adjust the forward (F) or Brake (B-reverse) travel adjustment, move the throttle trigger in the direction you wish to adjust and the opposite cursor will be removed.

Throttle Hold

Throttle hold moves the throttle servo to a pre-selected position when the TH.HOLD button is depressed. This can be adjusted to give full panic brakes for emergency braking. When throttle hold is on, all throttle settings (except sub-trim and reverse switch) are inactive, including throttle digital trim.

Note: Throttle Hold needs to be activated and set in System Mode, in the Function Select feature (refer to page 15).

Note: Activating Throttle Hold inactivates the timer as it uses the same button.

In Function Mode, access the Throttle Hold function by moving the cursor to THRO Hold and Pressing the MODE LIST key.

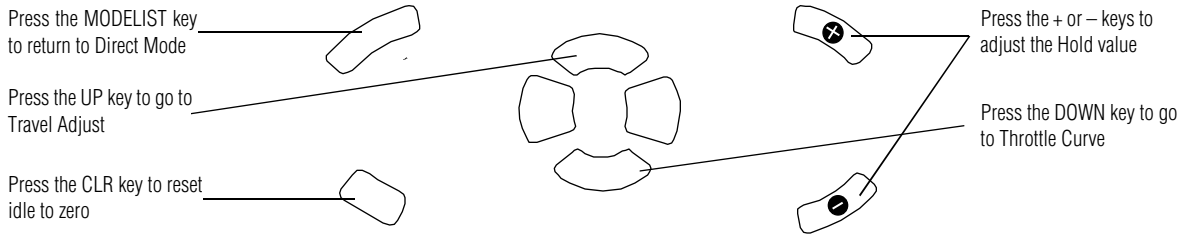
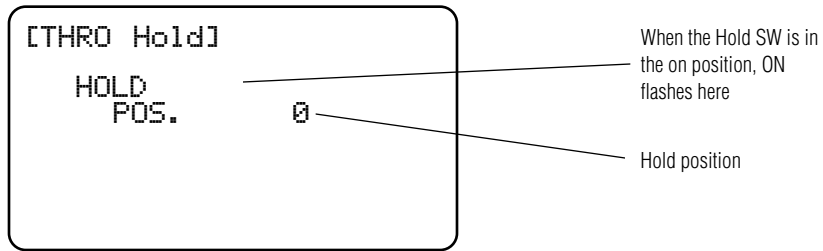

Range: F – 100% = Forward
B – 100% = Brake

Throttle Curve

The R-1 features an 8 point throttle that allows you to precisely adjust the throttle and brake response. Two 8 point curves can be set up, and each can be selected with the Drive Mode switch (position 0 or position 1).

In Function Mode, access the Throttle Curve function by moving the cursor to THRO CURV and pressing the MODE LIST key.

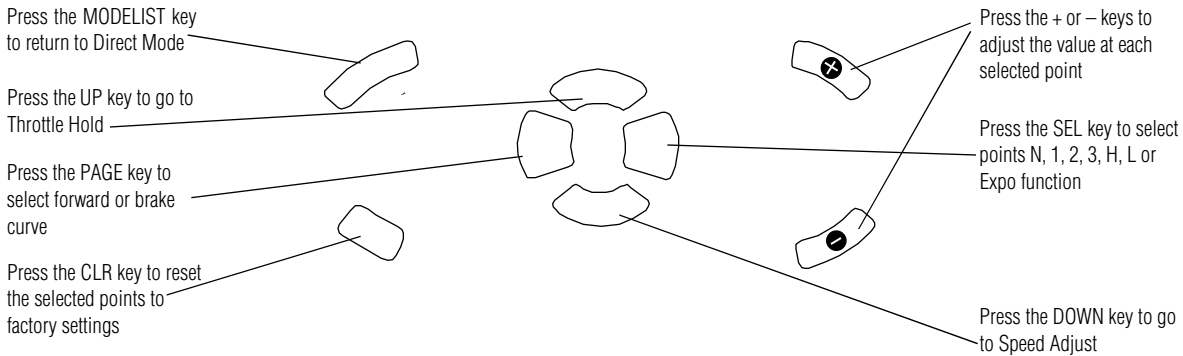
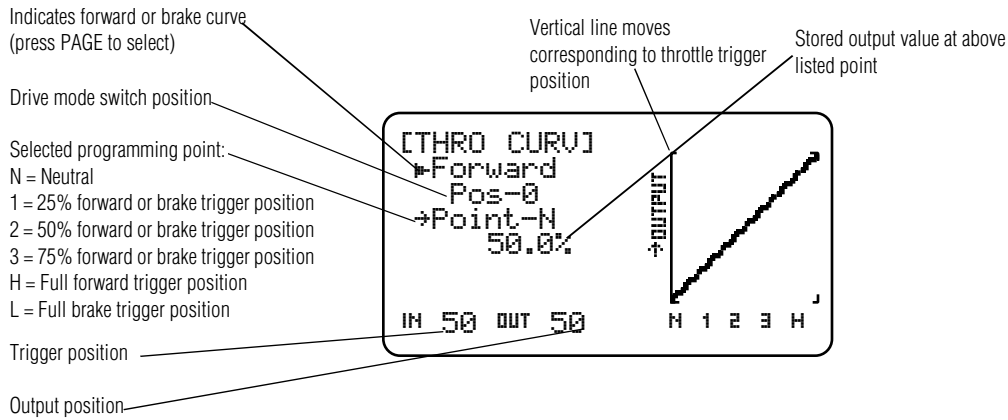

A digital graph shows the position of the servo (or throttle amount when using a electronic speed controller) at each throttle position (L, 3, 2, 1, N, 1, 2, 3, H). **Note:** The factory presets for the throttle curve is a straight (linear) response with positions N preset at 50%, 1 inhibited, 2 at 75%, 3 inhibited and H at 100%. To activate inhibited points, select that point and press the + or - key. The value at position N in forward and brake curve will always be 50% and can't be changed.

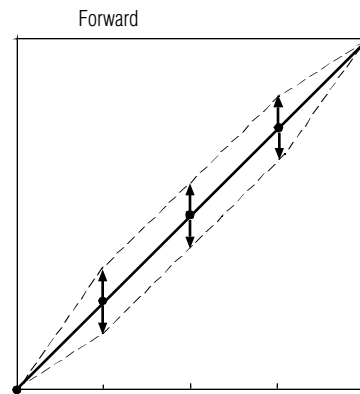

Each point can be selected and varied. On the forward curve, it can be adjusted from 50 to 100%, and on the brake curve from 50 to 0.

Exponential

An exponential function is available that is used to smooth out the throttle/brake curve. To activate the expo function, press the SEL key until EXPO appears at the center of the

screen. Press the + or - key to activate or deactivate the expo function. Also, pressing the CLR key in this screen will deactivate the expo function.

Indicates Expo is off. Press the + or - keys to turn the Expo on or off

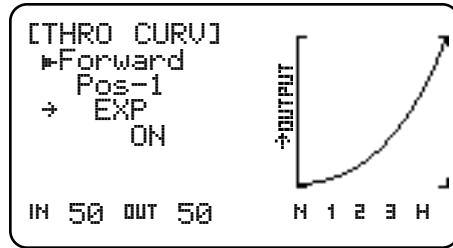
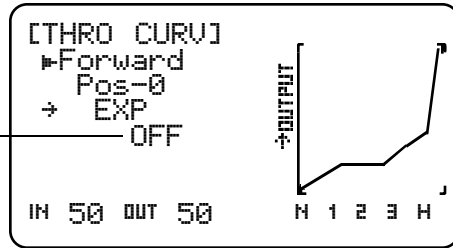

Function Mode

Speed Adjust

The R-1 allows you to adjust the steering servo's speed independently away from center (turning), as well as back to center (return). Also a point can be selected in both turning and return, and the speed between each point can be independently selected.

Two separate speed adjust values can be set and selected using the Drive Mode switch (position 0 or position 1).

In Function Mode, access the Speed Adjust function by moving the cursor to SPEED ADJ and pressing the MODE LIST key.

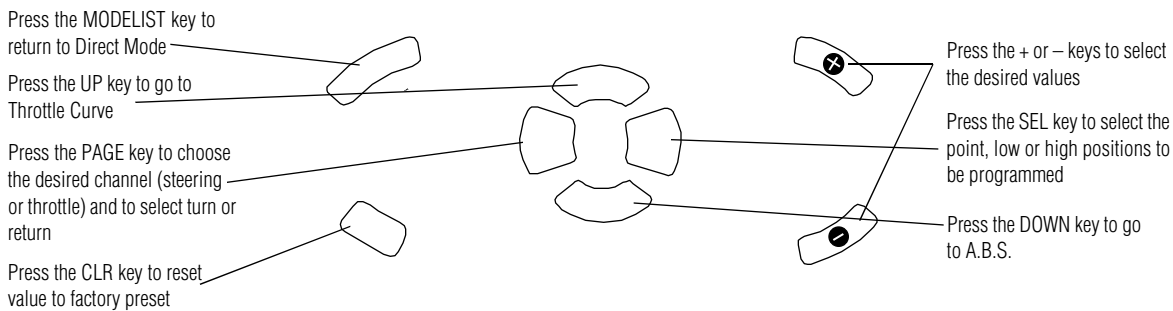
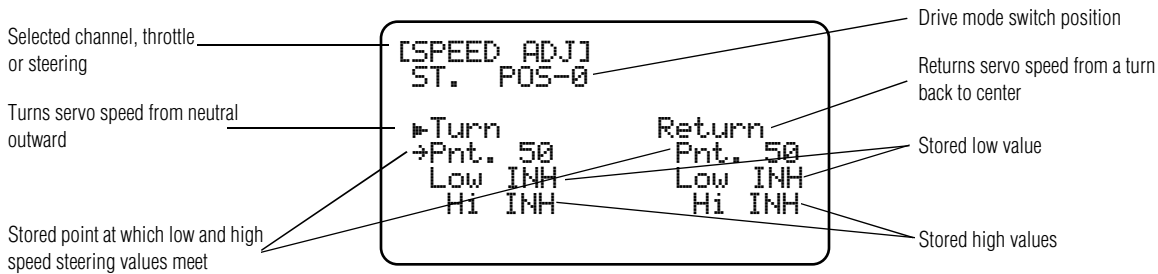

Note: When the Pnt. value is set at 0, the steering servo's speed is adjusted using the high value, and the low value will be ignored. If the Pnt. value is set at 100, the low value adjusts the servo speed. If you choose to use only one speed, then set the Pnt. to 0 and adjust using the high value.

Adjustment values can be set from 1 to 125. The smaller the value, the slower the servo speed.

Remember, two separate speed modes can be programmed and selected via the Drive Mode switch.

When the Speed Adjust function is turned on, SPEED will flash on the normal screen.

Advanced Braking System (A.B.S.)

The R-1 features the most advanced braking system available! A.B.S. works as a pulse brake, allowing greater stability and control during hard braking. The pulse width ("on" time versus "off" time) is called pattern, the pulse height (how hard the brakes pulse) is called swing, the braking point where A.B.S. actually begins is called start. A delay can be programmed so that regular braking occurs first, then

at a pre-set delay A.B.S. braking begins. Steering mixing is programmed to give increased A.B.S. braking as the steering wheel is turned (more A.B.S. is needed in the corners), plus a switch (Drive Mode) allows A.B.S. to be turned on/off.

In Function Mode, access the A.B.S. function by moving the cursor to A.B.S. and pressing the MODE LIST key.

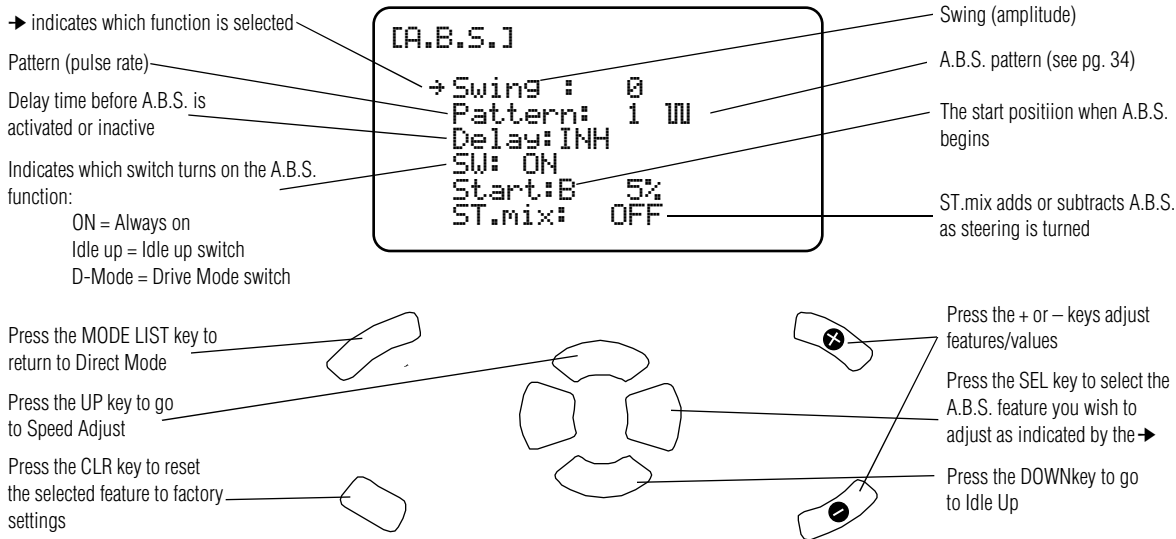

Swing

The swing adjustment affects how far (hard) the brakes travel during each pulse. This is the amplitude or strength of the pulse. **Note:** Regardless of any other A.B.S. brake setting, if

the swing value is set to 0, A.B.S. will be off (no pulse). When first trying swing, adjustments of approximately 60 are a good starting point.

Pattern

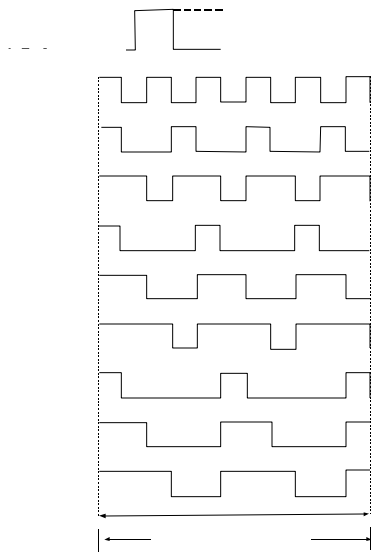

The pattern can be thought of as frequency, or how fast the pulses occur and the on time (brakes applied) versus off time (brakes off) during each pulse. Nine patterns are available (see above). Setting #1 is the fastest setting available with an on time of 50%. **Note:** The graph on the transmitter display shows the pattern. It visually gives the relative pulse rate and on versus off time.

Delay

With delay set at INH, A.B.S. braking begins immediately whenever brakes are applied on the throttle stick. Programming a delay value will allow standard proportional braking to take place for the pre-selected delay time. Then if the brakes are still applied, A.B.S. braking will occur.

If you'd like to see how this works, program a large value (near 100%) and watch what happens to the throttle servo as you apply brakes. Normally a value of 8 to 20 is used to give maximum initial braking before going into A.B.S. If your car spins out under heavy braking, your setting here may be too high.

Steering Mix

The steering mix feature is used to add A.B.S. braking when going into turns. Steering mix increases the swing range proportionately as steering input is given. Braking during cornering, your car is more likely to lose traction. With steering mix properly adjusted, harder braking can be achieved in the turns with complete control. **Note:** This feature also allows A.B.S. to be decreased (not used in most cases) as the steering wheel is turned by selecting a negative value here. Press the CLR key to turn off this function.

Switch

A.B.S. can be always left on (select ON), turned on/off with the Drive Mode switch (select DR.MODE) or with the Idle Up switch (select IDLE UP). **Note:** When A.B.S. is on, A.B.S. will flash on the normal screen.

Idle Up

The idle up function is normally used to advance the throttle position slightly, making it easier to start gas cars. When turned on, the throttle servo will offset to the pre-programmed position, and "on" will appear on the right side of the idle up screen.

In Function Mode, access the Idle Up function by moving the cursor to IDLE UP and pressing the MODE LIST key.

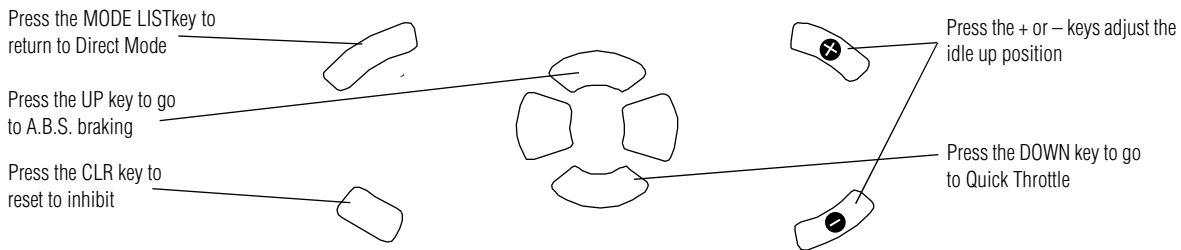
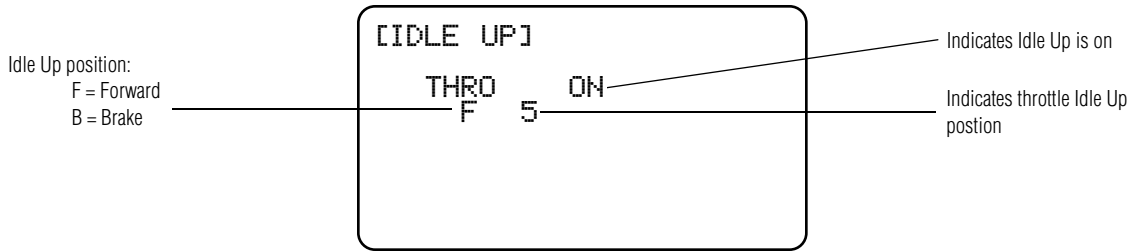

Quick Throttle

The quick throttle feature is used to reduce/eliminate the dead throttle area that exists at neutral to the starting point of throttle and from neutral to the starting point of braking. This area is sometimes known as dead band. As more throttle trim (also known as static brake) is applied, more of the dead trigger area right off neutral exists. Adjust a forward value such that your vehicle's wheels just start to turn when

the trigger is slightly squeezed. This gives the most accurate feel and eliminates this dead area.

In Function Mode, access the Quick Throttle function by moving the cursor to QUICK TH. and pressing the MODE LIST key.

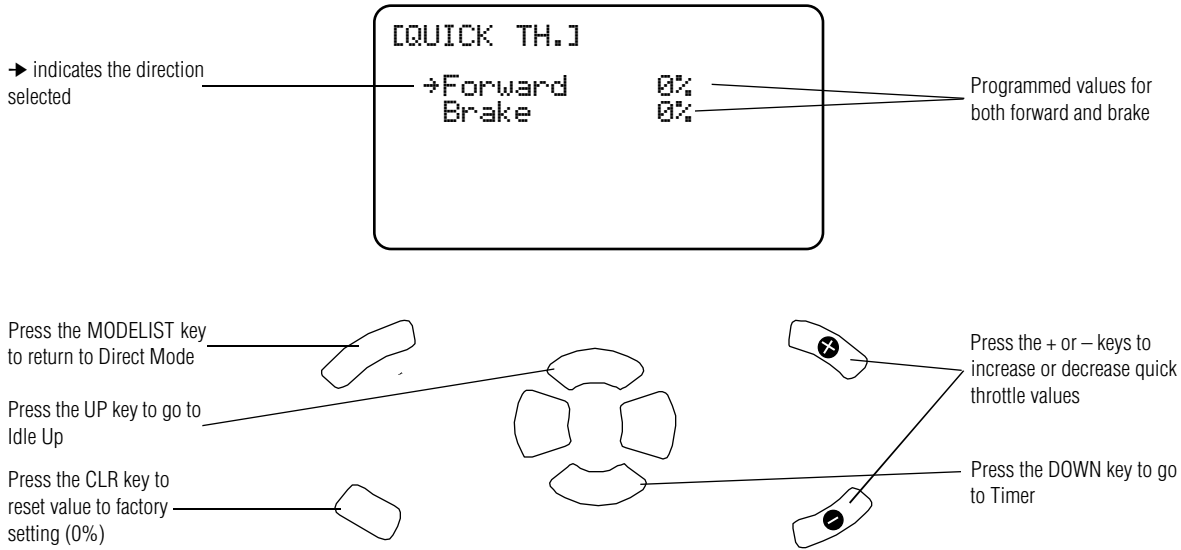

Experiment with brake values. You may want a higher than normal initial braking. If so, adjust a higher value on the brake side.

Timer

The below is a graphic illustration showing the flow path to get to up and down timer, as well as the individual lap times, lap calc and integrated timer.

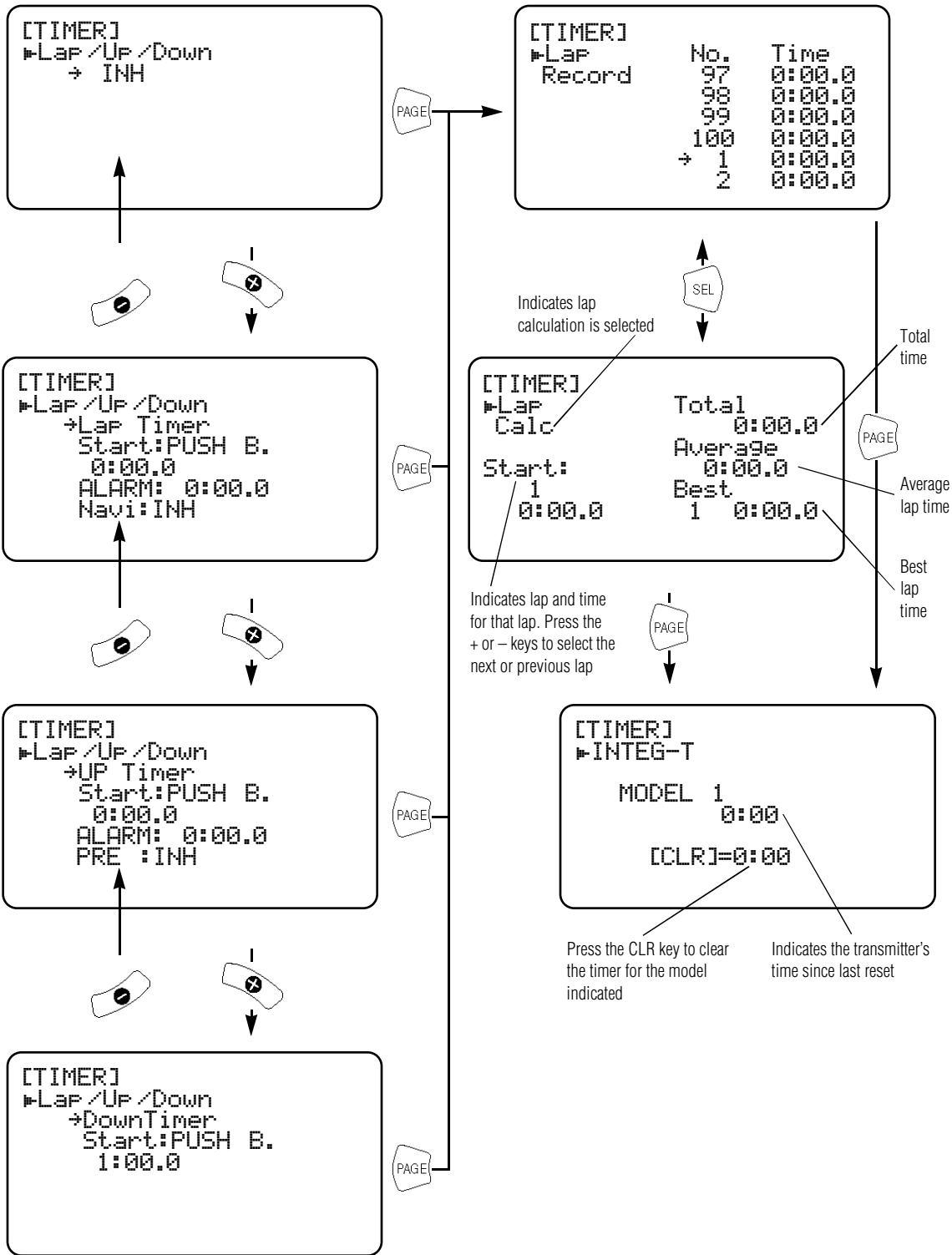

The R-1 features a sophisticated timing system. Three types of timers are available — a lap timer, an up timer and a down timer. There is also an integrated timer that gives the total time the transmitter has been on.

In Function Mode, access the Timer function by moving the cursor to TIMER and pressing the MODE LIST key.

Note: If throttle hold is selected on the timer button in the function select screen, the timer function is inhibited and will not appear on the function list.

Press the + or – keys to select:
Lap Timer
Up Timer
Down Timer

```
[TIMER]
└Lap/Up/Down
  └Lap Timer
    Start:PUSH B.
    0:00.0
    ALARM: 0:00.0
    Navi:INH
```

Press the SEL key to select the desired feature to program

Before lap timer can be started, any time must be cleared on this screen.

Lap Timer

The lap timer allows the recording of each lap, and individual laps can be recalled/displayed. This function also calculates average lap time and best lap. Up to 100 laps and up to 99 minutes and 59 seconds can be stored in memory. The lap timer can be started with the lap button or automatically

started when the throttle is pressed. An alarm can be preset, signaling the end of the race time. A navigation timer can be set to a fast lap time, and an alarm will sound at that preset interval. Noting the position of the car on the track when this alarm sounds gives an indication as to the relative lap time.

Note: Lap timer will be displaying on the main info screen when activated. Also, when lap timer is activated and you're in the normal display screen, you can pause the lap timer by pressing the PAGE key. To clear any of the lap times, you must first "un-pause" the lap timer.

Note: A three-second lap is the quickest lap allowed. This prevents accidentally double pushing the button when recording a lap time.

Indicated present lap. Press the + or the – keys to select the desired lap

```
[TIMER]
└Lap Record
  No.   Time
  97   0:00.0
  98   0:00.0
  99   0:00.0
  100  0:00.0
  → 1   0:00.0
  2    0:00.0
```

Note: Pressing the CLR key will zero out the selected lap. Press the CLR key twice more to clear out all laps.

```
[TIMER]
└Lap Calc
  Start:
  1      0:00.0
  Total
  0:00.0
  Average
  0:00.0
  Best
  1 0:00.0
```

Up Timer

The up timer functions like a stopwatch counting up. The timer can be started with the lap timer button or automatically when the throttle is pressed. An alarm can be preset to go off at a preselected time (usually set to the length of the race to check run time during practice). A pre-timer (or navi timer) can be preset to a quick lap time. An alarm will then sound at each interval, and judging the relative position on the track, the driver can determine his relative lap time.

Down Timer

The down timer counts down from a preset time (normally the length of the race), then sounds an alarm. This timer function is used for checking run time. The countdown timer can be started with the lap button or automatically when the throttle is pressed.

Integrated Timer

The integrated timer keeps track of the time the transmitter is turned on, which is useful for determining how much battery life is left. Press the PAGE key to access the above screen. Also note that Integrated Timer is displayed on the normal screen.

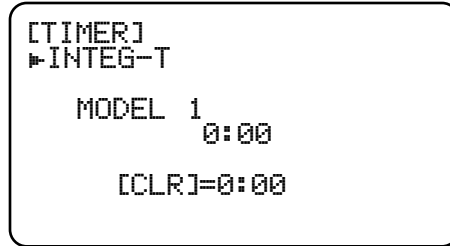

How to Start the Timer

PUSH B

The timer can be manually started with the thumb button. Selecting the PUSH B position after START allows the timer to be activated when the thumb button is pushed.

TH.AUTO

The timer can automatically be started when the throttle is pulled. Select the TH.AUTO position after START. Now in the info screen, press the CLR key to activate the auto timer. “Ready” will flash at the lower screen. Now pulling the throttle will start the timer.

Pausing and Resetting the Timers

Down Timer and Up Timer— To pause the up or down timers, press the thumb button once. To restart the timer press the thumb button again. To reset the up or down timers, press the CLR key.

Lap Timer— In the normal screen, pause the lap timer by pressing the PAGE key. To restart the timer, press the PAGE key again. To stop the lap timer, access the timer function and move the arrow using the SEL key to the time display. Pressing the CLR key will reset the lap timer.

Note: This will not reset the individual lap times. To reset the lap time, press the PAGEkey to access the screen that displays the laps. Use the + or - keys to move the cursor to the lap that you wish to reset. Then press the CLRkey to reset that lap. Pressing the CLRkey twice more will clear out all the laps.

Model Select

The R-1 has the ability to store up to ten models in its memory. All programmed parameters, including digital trim positions, are automatically stored in each memory.

In Function Mode, access the Model Select function by moving the cursor to Model SEL and pressing the MODE LIST key.

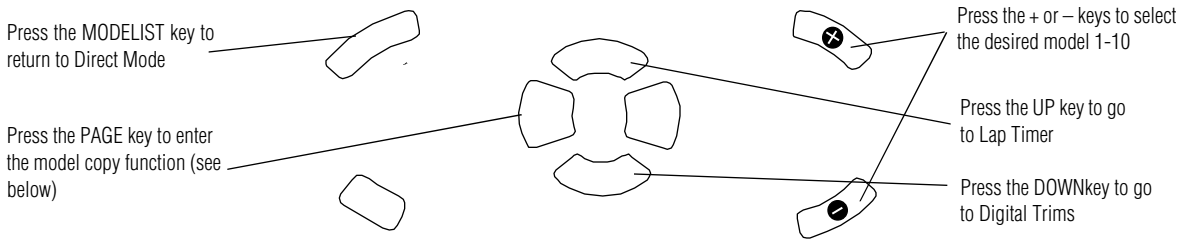
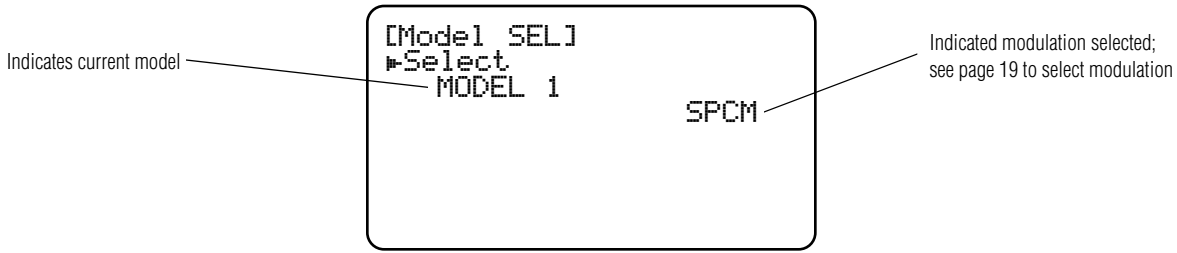

In the Model Select mode a copy function is available that allows you to copy the model that you're in to another selected program. This can be used to set up the same

model for different tracks. To enter the model copy, press the PAGE key after entering the Model Select function.

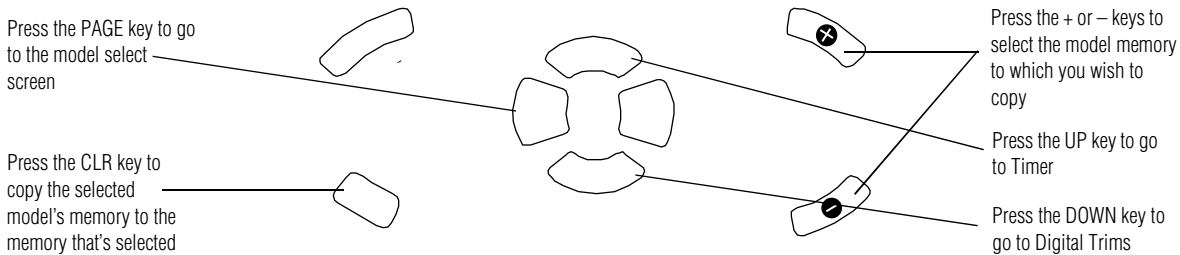
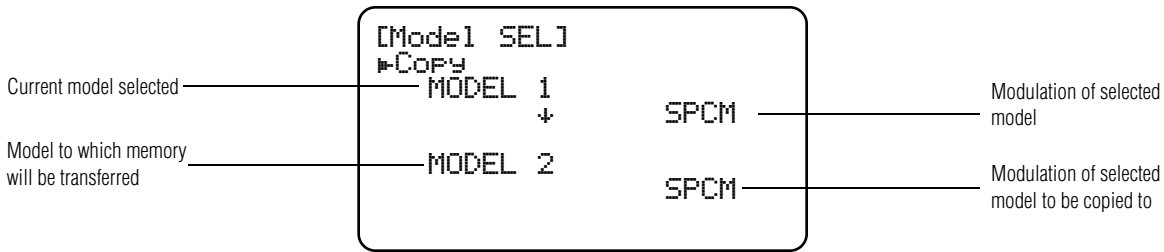

Position (Digital Trim and Servo Position)

The POS. screens visually display the digital trim positions and the servo positions. This can be helpful when making adjustments or to see how programming changes (e.g., mixing or throttle curve) affect the servo's movement.

In Function Mode, access the Position function by moving the cursor to POS. and pressing the MODE LIST key.

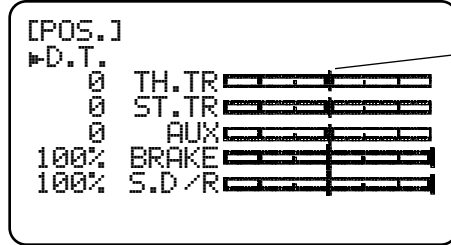

The cursor indicates the position of the trim

Press the PAGE key to alternate between these two screens

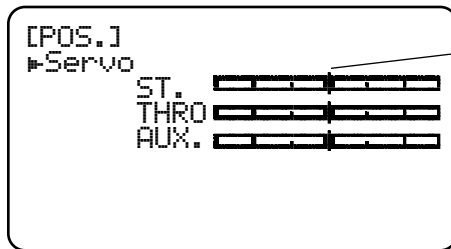

The cursor indicates the servo position

Press the PAGE key to alternate between the above two screens

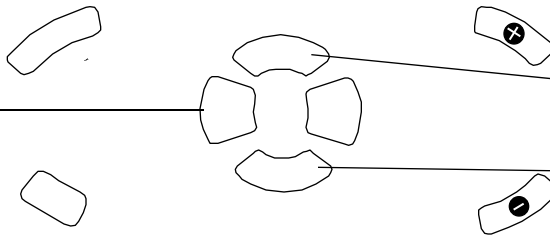

Press the UP key to go to Model Select

Press the DOWN key to go to Dual Rate/Expo

Data Sheet

MODEL NO. _____

MODEL NAME _____
 MODULATION PPM • SPCM • ZPCM
 TX MODE Expert • Beginner

	STEERING	THROTTLE	AUX(ch3)
REVERSES/W	NORM REV	NORM REV	NORM REV
TRAVEL ADJUST	L % H % + % R % L % - %		
SUB-TRIM			
FAIL-SAFE			
TRIMRATE			

		DRIVE MODE	EXP	N/L	1/3	2	3/1	H/N
THRO	Forward	0	OFF•ON	%	%	%	%	%
		1	OFF•ON	%	%	%	%	%
CURVE	Brake	0	OFF•ON	%	%	%	%	%
		1	OFF•ON	%	%	%	%	%

		DRIVE MODE	Pnt.	Low	High
SPEED ADJUST	ST. Turn	0		INH•	INH•
		1		INH•	INH•
	ST. Return	0		INH•	INH•
		1		INH•	INH•
TH. Turn	0		INH•	INH•	
	1		INH•	INH•	

		DRIVE MODE	RATE	A.B.S	
STEERING	EXP	0	%	SWING	
		1	%	PATTERN	
	D/R	0	%	DELAY	INH•
		1	%	SW	
				START	B %
				ST.mix	OFF ± %

THRO HOLD	F•B
-----------	-----

QUICK TH.	Forward	%	IDLE UP	F•B
	Brake	%		

		CHANNEL	SW	+POS	-POS	OFFSET
PROGRAM MIX	1	➔		%	%	
	2	➔		%	%	

TOTALTIME: ' "		ALARM	
LAP TIME LIST		Best: ' "	
1	' "	51	' "
2	' "	52	' "
3	' "	53	' "
4	' "	54	' "
5	' "	55	' "
6	' "	56	' "
7	' "	57	' "
8	' "	58	' "
9	' "	59	' "
10	' "	60	' "
11	' "	61	' "
12	' "	62	' "
13	' "	63	' "
14	' "	64	' "
15	' "	65	' "
16	' "	66	' "
17	' "	67	' "
18	' "	68	' "
19	' "	69	' "
20	' "	70	' "
21	' "	71	' "
22	' "	72	' "
23	' "	73	' "
24	' "	74	' "
25	' "	75	' "
26	' "	76	' "
27	' "	77	' "
28	' "	78	' "
29	' "	79	' "
30	' "	80	' "
31	' "	81	' "
32	' "	82	' "
33	' "	83	' "
34	' "	84	' "
35	' "	85	' "
36	' "	86	' "
37	' "	87	' "
38	' "	88	' "
39	' "	89	' "
40	' "	90	' "
41	' "	91	' "
42	' "	92	' "
43	' "	93	' "
44	' "	94	' "
45	' "	95	' "
46	' "	96	' "
47	' "	97	' "
48	' "	98	' "
49	' "	99	' "
50	' "	100	' "

Warranty Information

Important Note: Be sure to keep your original, dated sales receipt in a safe place as you will be required to provide proof-of-purchase date for the equipment to be serviced under warranty.

Warranty Coverage

Your new JR Remote Control Radio System is warranted to the original purchaser against manufacturer defects in material and workmanship for 365 days from the date of purchase. During this period, HORIZON SERVICE CENTER will repair or replace, at our discretion, any component that is found to be factory defective, at no cost to the purchaser. This warranty is limited to the original purchaser of the unit and is not transferable.

This warranty does not apply to any unit which has been improperly installed, mishandled, abused, or damaged in a crash, or to any unit which has been repaired or altered by any unauthorized agencies. Under no circumstances will the buyer be entitled to consequential or incidental damages. This limited warranty gives you specific legal rights; you also have other rights which may vary from state to state. As with all fine electronic equipment, do not subject your radio system to extreme temperatures, humidity or moisture. Do not leave it in direct sunlight for long periods of time.

Repair Service Directions

In the event that your JR radio needs service, please follow the instructions listed below:

1. Check all on/off switches to be sure they are off. This will speed the repair process of checking battery condition.
2. Return your system components only (transmitter, receiver, servos, etc.) Do not return your system installed in a model aircraft.
3. Preferably, use the original carton/packaging (molded foam container), or equivalent, to ship your system. Do not use the system carton itself as a shipping carton. You should package the system carton within a sturdy shipping container using additional packing material to safeguard against damage during transit. Include complete name and address information inside the carton, as well as clearly writing it on the outer label/return address area.

4. Include detailed information explaining your operation of the system and problem(s) encountered. Provide an itemized list of equipment enclosed and identify any particular area/function which may better assist our technicians in addressing your concerns. Date your correspondence, and be sure your complete name and address appear on this enclosure.

5. Include your name, mailing address, and a phone number where you can be reached during the business day.

6. Warranty Repairs. To receive warranty service, you must include your original, dated sales receipt to verify your proof-of-purchase date. Providing that warranty conditions have been met, your radio will be repaired without charge.

7. Normal Non-Warranty Repairs. Should your repair cost exceed 50% of the retail purchase cost, you will be provided with an estimate advising you of your options.

Within your letter, advise us of the payment method you prefer to use. HORIZON SERVICE CENTER accepts VISA or MasterCard, or we can return C.O.D. cash-only. If you prefer to use a credit card, include your card number and expiration date.

Mail your system to:

Horizon Service Center
4105 Fieldstone Road
Champaign, IL 61821
Phone: (217) 355-9511