

# XR3

3 Channel, 3 Model Memory  
FM Computer Racing System



**JR RACING**

# Table of Contents

---

Introduction to the XR-3 Radio System	2	Lithium Battery	10
XR-3 Quick Start Setup	3	Memory Backup Screen	10
Direct Trim Access	4	Accessing the System Mode	11
Servo Trim Adjustment	4	Model Name Entry	12
System Features	5	Data Reset	13
Transmitter Features	5	Channel 3 Function Select	14/15
Receiver Features	5	Accessing the Function Mode	16
Servo Features	5	Model Select	17
System Specifications	5	Travel Adjust	18/19
System Components	5	Steering Rate	20
Transmitter Specifications	5	Sub-Trim	21
Receiver Specifications	5	Servo Reversing	22
Servo Specifications	5	Accessing the Direct Trim Mode	23
Control Identification and Location	6	Steering Trim	24
R/C Safety Precautions	7	Throttle Trim	24
Steering Tension Adjustment	7	Grip Lever B: Steering Dual Rate Trim Adjustment STG	25
Charging Jack	7	Grip Lever A: Brake Endpoint Adjustment BRG /Channel 3 Access Brake Endpoint Adjustment	26
Receiver/Servo Connections and Installation	8	Channel 3 Access	27
Operating Your Model	9	XR-3 Data Sheets	28/29
Servo Layout	9	Frequency Chart	30
Key Input and Display	9	Warranty and Service Information	31
Display Screens	10		
Normal Display Screen	10		
Low Battery Screen	10		

## Introduction to the XR-3 Radio System

Thank you for purchasing the XR-3 three-channel radio system. This system has been designed to provide R/C racers with a high quality, user friendly radio system that can be relied upon year after year, race after race. In addition, the XR-3's grip dial accessible third channel is ideal for use as a mixture channel in gas boats, or as a transmission shifter for specific Tamiya®-equipped R/C trucks. It's important that you carefully read this manual before attempting to operate your XR-3 system. For your convenience, a blank data sheet has

been included in the back of this manual. Once you have input all the necessary data for a particular model into your transmitter, we strongly recommend that you immediately write that information down on the data sheet provided. This insures that, in the rare case of a memory failure, you will not lose your models' set-up data.

For those who would like to get out to the track quickly with just the basic radio set-up, please refer to the Quick Start section that follows.

## XR-3 Quick Start Setup

Included in this manual are in-depth instructions detailing all the steps and procedures needed to correctly program each of the XR-3's features. For those racers who want to get to the track fast, we have provided the Quick Start section below. Quick Start covers the basic programming information necessary to get you to the track fast.

Later, when you want to learn more about the specific features of the XR-3, refer to the appropriate page(s) in this manual for more detailed programming information.

**Note:** If braking adjustment via Grip Dial A is required, refer to the third channel system set up mode (Page 14) for instructions.

## Servo Reversing



1. With the transmitter power switch on, press the MODE key to enter the Function Mode.



2. Press the MODE key four times until ST appears on the screen. The ST indicates the steering servo reversing screen.

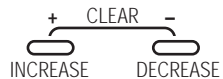

3. Press the INCREASE or DECREASE key to move the cursor to the desired servo direction (Rev.Norm).



4. Press the CHANNEL key once to access the throttle servo reversing screen.
5. To select the direction of the throttle servo, repeat Step 3 above.
6. Repeat Steps 2 and 3 to adjust channel 3 if needed.

## Travel Adjustment

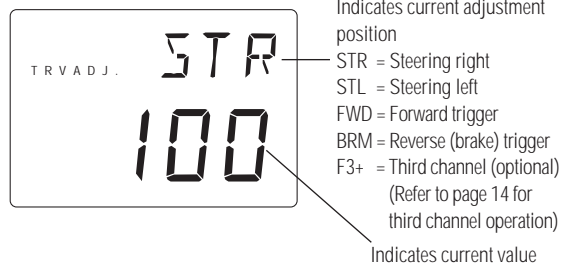

1. From the Servo Reverse function, press the MODE key twice to access the Travel Adjustment function (the STR or STL screen will appear).

## Steering Adjustment:

2. Rotate the steering wheel in the desired direction (left or right) to be adjusted.



3. Press the INCREASE or DECREASE keys to select the desired travel value.

## Throttle Adjustment:



4. Press the CHANNEL key once. FWD will appear on the screen.



5. Press the INCREASE or DECREASE keys to select the desired travel value.

## Channel 3 Adjustment:

If third channel is not required, proceed to Step 8.



6. Press the CHANNEL key once. F3+ will appear on the screen.

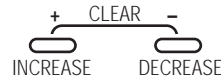

7. Press the INCREASE or DECREASE keys to select the desired travel value.



8. Press the MODE and CHANNEL keys at the same time to exit the function mode.

# Direct Trim Access

## Servo Trim Adjustment

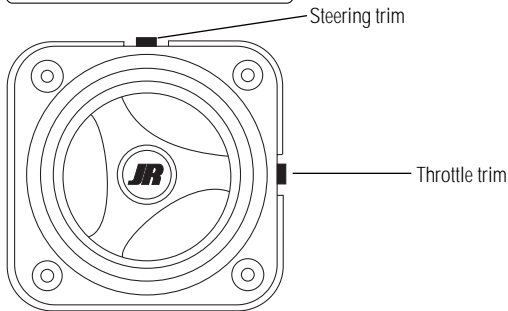
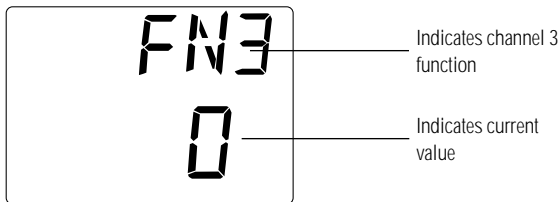
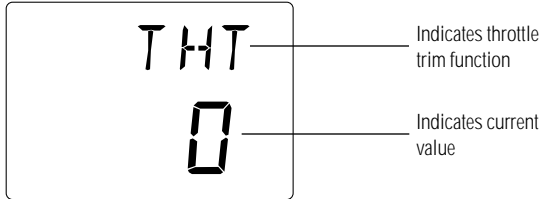
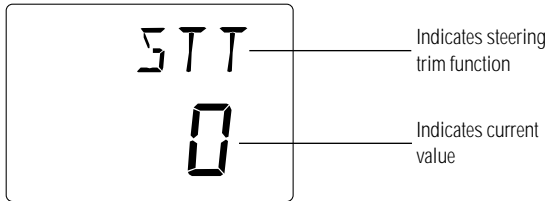

## Steering Servo Trim Adjustment:

1. With the transmitter power switch on, move the digital steering trim lever in the desired position to be adjusted. The steering trim value screen will appear automatically.

## Throttle Servo Trim Adjustment:

2. With the transmitter power switch on, move the digital throttle trim lever in the desired position to be adjusted. The throttle trim value screen will appear automatically.

## Channel 3 Servo Trim Adjustment

### (If Activated):

3. With the transmitter power switch on, move the digital Grip Lever A in the desired position to be adjusted. The channel 3 value screen will appear automatically.

Diagram A

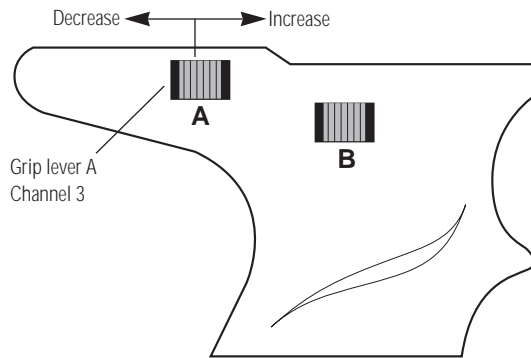

# System Features

## Transmitter Features

- Three Channels
- FM modulation
- Easy-to-read LCD graphics display
- Three model memory
- Three-character model name entry
- Electronic digital trim levers for throttle and steering
- Two assignable electronic grip levers
- Third channel accessible through Grip Dial A
- Direct display trim function
- Servo reversing
- Sub-trim
- Steering dual rate
- Steering endpoint adjustment (two points — left and right)
- Brake/throttle endpoint adjustment
- Low battery alarm
- Plug-in crystals
- Charge jack receptacle (rechargeable batteries not included; order JRPB958)

## R-133 Receiver Features

- Three Channels
- FM modulation
- 27MHz/75MHz available
- Battery eliminator circuitry (BEC)
- Patented ABC&W interference technology

## Z250 Servo Features

- Low current drain
- Indirect drive feedback potentiometer for additional vibration protection
- Surface Mount Technology (SMT)
- Durable nylon gear train for long life

# System Specifications

## System Components

System name	XR-3
Transmitter	NET XR-3
Receiver	R-133
Servos	Z250 × 2 (1 if equipped with ESC speed control)
Accessories	B.E.C. switch harness with battery case, servo accessories (for two servos), instruction manual

## XR-3 Transmitter Specifications

Model number	XR-3
Encoder	3-channel computer system
RF output	27/75 MHz
Modulation	FM modulation
Output power	195.0 Mw
Current drain	150 mA
Power source	1.5V × 8 dry cell (1.2V × 8 NiCad 600 mAh optional)
Output pulse	1000–2000 (1500 neutral)

## R-133 Receiver Specifications

Model Number	NER-133
Type	3-channel/FM ABC&W circuitry
Frequency	27/75 MHz
Sensitivity (microseconds)	5qs minimum
Selectivity	8 KHz/50dB
Weight (oz)	.88 oz
Size (in) (WxLxH)	1.26 × 1.76 × .87
Receiver antenna	14.75"
Power Supply	4.8–6.0V D/C

## Z250 Servo Specifications

Torque (oz/in)	40.3 oz/in
Speed	.25sec/60°
Weight (oz)	1.47 oz
Size (in) (WxLxH)	0.73 × 1.52 × 1.32
Motor	3-pole ferrite type

# Control Identification and Location



\*To remove, press down where it says "press" and push the cover in the direction of the arrow. Remove the battery case and install eight AA batteries in the direction shown as molded into the battery case. If transmitter voltage fails to register, check for correct battery installation and voltage.

## R/C Safety Precautions

For safe and reliable performance of your R/C model, please carefully read and follow these guidelines:

1. Radio control models are not toys. They are capable of inflicting serious injury to people and property. Use caution at all times when operating your model.
2. You are responsible for the safe operation of your R/C model. You must properly install, test and operate your model with a clear sense of that responsibility. Do not take risks that might endanger yourself or others.
3. Running an R/C car in the streets is very dangerous to both drivers and models. Avoid running your model in areas occupied by full size automobiles. To locate areas where you can safely operate your model, you should contact your local hobby shop for R/C tracks or clubs in your area.
4. When running an R/C boat, keep it away from any swimmers, full size boats, or wildlife. Also, watch carefully for fishing lines that can get tangled in the propeller.
5. Before operating your model, make sure your frequency is clear. If someone else is operating on the same frequency, both models will go out of control, possibly causing damage to the models, as well as others.
6. If at any time while operating your R/C model you sense abnormal model functioning, end your operation immediately. Do not operate your model again until you are certain the problem has been corrected.

**CAUTION:** Control of your model is impossible without sufficient voltage for the transmitter and receiver. A weak transmitter battery will decrease your range of operation and a weak receiver battery will slow servo movement and decrease your range of operation. Check your receiver pack voltage often to avoid losing control of your model. When using a model that operates both the electric motor and the receiver from the same battery (Battery Eliminating Circuitry, or B.E.C.), you should discontinue use when the top speed sharply decreases or you'll quickly lose control of your model.

## Steering Tension Adjustment

Steering tension is adjustable via the recessed screw located beneath the steering wheel (see page 6 for exact location). Turning the screw clockwise increases the steering tension.

## Charging Jack

Located on the right-hand side of the transmitter is the charging jack, which accepts only JR wall chargers. Please do not attempt to use any other brand of wall charger as it may be reverse polarity and can cause damage to your system. Only use the JR wall charger when the XR-3 is equipped with Ni-Cad batteries (available separately, JRPB958).

JR TRANSMITTER CHARGE JACK POLARITY: 

Charger Pigtail For Transmitter

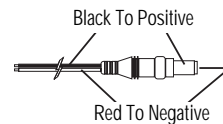

# Receiver/Servo Connections and Installation

Your R-133 Receiver is equipped with Battery Eliminator Circuitry (B.E.C.). The receiver gets its power from the model's Ni-Cad battery pack, thus saving the weight of an additional receiver battery. Ni-Cad batteries from 4.8–8.4V (4–7 cells) can be used safely. Higher voltage packs may damage the receiver and servos.

**Note:** When using a separate receiver Ni-Cad as a power source, the operating voltage range is 4.8–6.0V (4–5 cell)

**Attention:** Make sure the male and female connectors have the correct polarity (+/-) before connecting. The servo lead and receiver case are molded so that the lead can only be inserted correctly. Be sure to orient the servo plug correctly for proper insertion.

You may use a separate receiver battery to power the receiver (such as for some electric boats or in gas-powered vehicles). A Ni-Cad pack plugged into the BATT socket on your receiver will operate your receiver. You can also use alkaline batteries with the included battery box.

If you use a mechanical speed controller, please make sure it has the correct connector for a B.E.C. system (red connector). See Figure A below for a typical setup.

Most electronic speed controllers are set up for B.E.C. operation and plug directly into your receiver (Function 2). See Figure B for a typical set-up and check your speed controller's manual for correct installation.

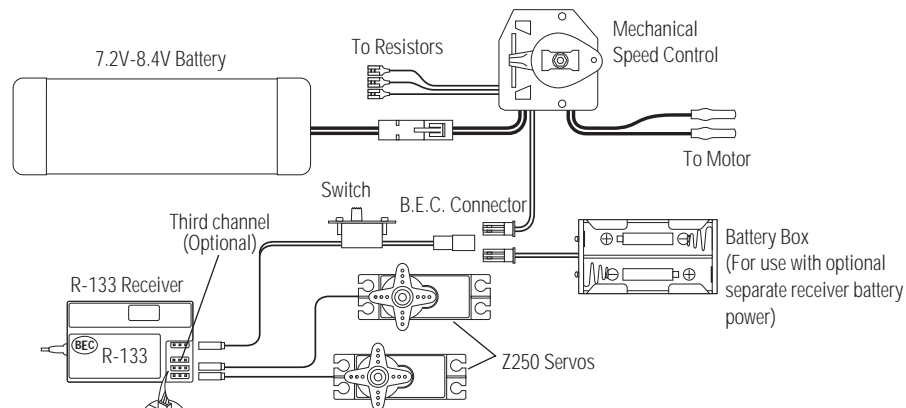

**Figure A** – Connections to B.E.C. receiver with mechanical speed controller. Ni-Cad battery and speed controller are not included in the radio set.

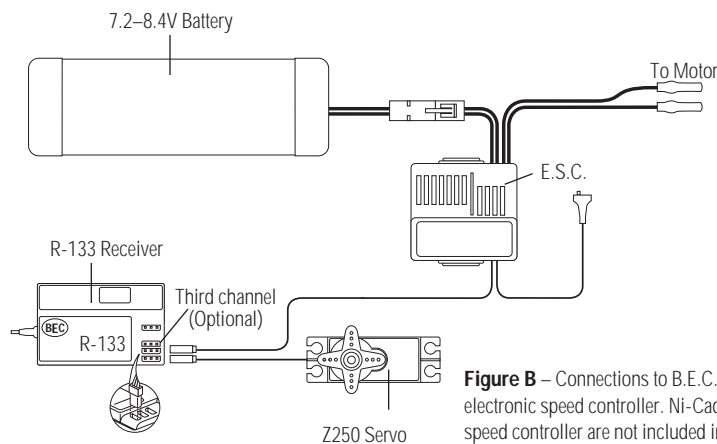

**Figure B** – Connections to B.E.C. receiver with electronic speed controller. Ni-Cad battery and speed controller are not included in the radio set.

# Operating Your Model

It's important to learn the proper sequence for switching on/off your radio system:

**BEFORE OPERATION:** Switch on the transmitter, then the receiver.

**AFTER OPERATION:** Switch off the receiver, then the transmitter.

This ensures that you will always have a signal to the receiver, and your R/C model will not operate out of control when you turn off the transmitter.

# Servo Layout

**Note:** Rubber grommets and (sometimes) eyelets are used in fuel-powered vehicles.

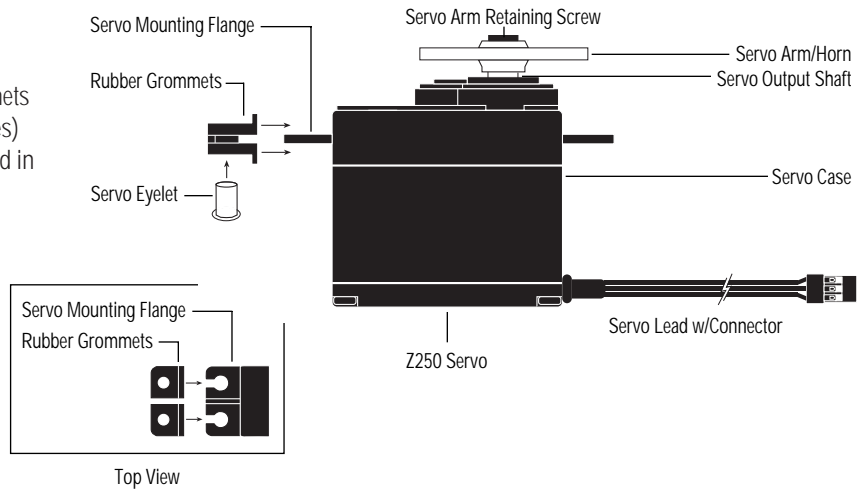

# Key Input and Display

KEY	USE
MODE	Used to move up through the available functions
CHANNEL	Used to select the desired channel
INCREASE	Used to increase the value of the selected function
DECREASE	Used to decrease the value of the selected function

To enter the System Mode press the MODE and CHANNEL keys simultaneously and hold while turning on the transmitter.

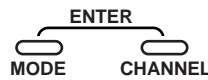

To enter the Function Mode press the MODE key while the transmitter is on.

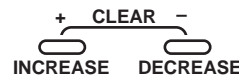

Press the INCREASE and DECREASE keys simultaneously to clear the screen or return to factory preset.

## Display Screens

### Normal Display Screen

When the power switch is turned on, the LCD screen will read as shown below. This screen is referred to as the Normal Display.

**Note:** If any of the electronic trim buttons are moved while in this screen, the screen will automatically change to display the trim in use. This is called the Direct Trim Mode. For more information on the feature, please see page 23 of this manual.

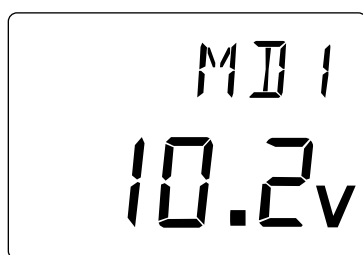

### Low Battery Screen/Lithium Battery Backup

When the voltage of the eight AA batteries drops below 9.0 volts, the XR-3's display screen will alternate between the Normal (see above) and Low Battery screen (BATT), and a continuous beeping will occur, indicating that the batteries need to be replaced before further use. The Low Battery screen is active during any of the three operating modes.

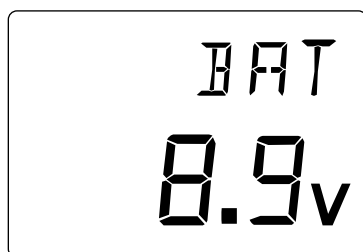

### Lithium Battery

Your XR-3 radio system is equipped with a five year lithium battery backup system. This system is designed to protect and retain all radio programming in the event that the transmitter batteries drop below the required 9.0 volts, or the transmitter battery case is removed during battery changes. If after five years it becomes necessary to replace the lithium battery, return your system to the Horizon Service Center for repair (see address, page 31).

### Memory Backup Screen

If the Memory Backup screen appears, this indicates that any programming changes made since the last time the system was turned on must be saved by pressing the MODE and CHANNEL buttons at the same time. If you do not save, the recent programming changes will be lost. If this screen appears for a second time, it is suggested that the XR-3 transmitter be returned to the Horizon Service Center for servicing (see Warranty Information, page 31).

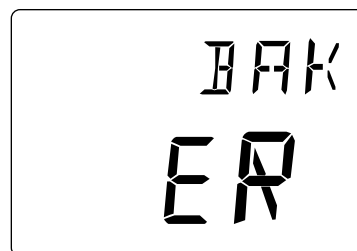

## Accessing the System Mode

To enter the System Mode, press both the MODE and CHANNEL keys at the same time while turning on the transmitter power switch. By pressing the MODE key, you can now select the model name input, data reset function or channel 3 function as shown here on the System Mode flow chart. Information for each function is located on the page number listed next to the function name on the flow chart.

To exit the System Mode, press the MODE and CHANNEL keys at the same time, or simply turn off the transmitter.

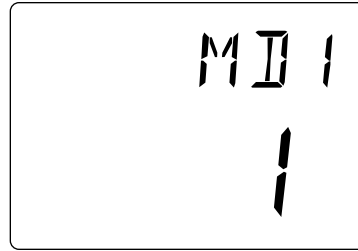

Model Name Entry,  
page 12

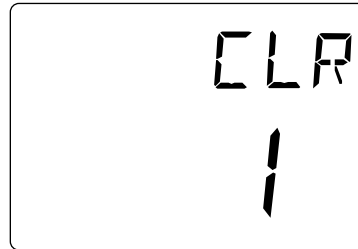

Data Reset, page 13

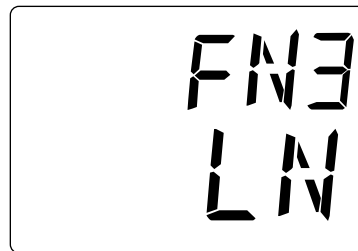

Channel 3 Function,  
pages 14–15

# Model Name Entry (System Mode)

The XR-3 allows a three-character name to be input for each of the three (3) models available. The current model, with name, will then be displayed in the Normal display screen. This feature is useful to help identify different models, setups, etc. For information on selecting models 1, 2 or 3, please refer to the Model Select Function (page 17).

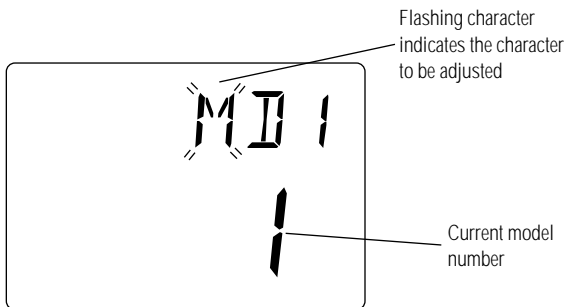

## Accessing the Model Name Entry Function

To access the Model Name Entry function, follow the steps below:

Press and hold the MODE and CHANNEL keys at the same time to enter the System Mode

Press the CHANNEL key to select the character to be changed

Press the increase or decrease keys to select the correct letter/number to be used

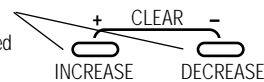

1. Press the MODE and CHANNEL keys at the same time and hold.
2. Turn on the transmitter power switch to enter the System Mode.
3. MD1 should now be present on the screen.
4. Press the INCREASE or DECREASE keys to select the correct letter/number for the first character (flashing).
5. To change the remaining two characters, press the CHANNEL key until the desired character to be changed is flashing.
6. To access the Data Reset function, press the MODE key. To exit the System Mode, either turn the transmitter power switch off or press the MODE and CHANNEL keys at the same time.

## Data Reset (System Mode)

The Data Reset function allows you to reset all the programming in the selected model (1, 2 or 3) to the factory default settings. Before using the Data Reset function, it's important to enter the Model Select function and check to make sure the current model number indicated (1, 2 or 3) is the model to which you want to reset to the factory default settings. The Model Select function is described in on page 17.

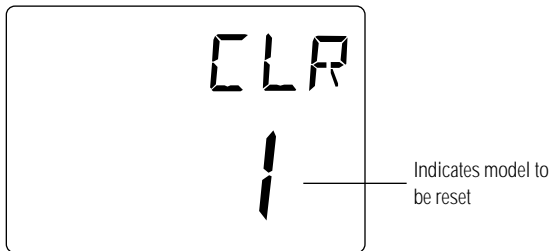

## Accessing the Data Reset Function

To access the Data Reset function, follow the steps below:

Press the MODE key to access the Model Name Entry function

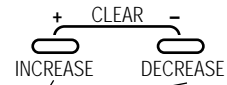

Press the INCREASE and DECREASE keys at the same time to reset (clear) all settings for the selected model to the factory default settings

1. Press the MODE and CHANNEL keys at the same time and hold.
2. Turn on the transmitter power switch to enter the System Mode.
3. Press the MODE key once until CLR appears on the screen.
4. Press the INCREASE and DECREASE keys at the same time to reset the data. To confirm that the selected model's programming has been reset, a beep will sound and the model number selected (1, 2 or 3) will stop flashing.
5. To exit the System Mode, either turn the transmitter power switch off or press the MODE and CHANNEL keys at the same time.

## Channel 3 Function Select (System Mode)

The Channel 3 function of the XR-3 allows you to select from 2 different types of Channel 3 servo travel movements, or to inhibit the Channel 3 function so that the Grip Dial A can be used to operate the brake endpoint adjustment feature. Use the information below to select the correct Channel 3 function type for your particular installation. It is suggested the 0 function be selected for most applications.

(factory preset)

**LN** = The LN, or linear, servo travel function is designed to be used when an engine fuel mixture servo is required. This function is most commonly used with gas powered R/C racing boats. As mentioned previously, this function is accessible through the Grip Dial A. In this function, the maximum travel of the servo is determined by the travel adjust function, page 18. The servo neutral position can be altered proportionately via the Grip Dial A for fuel mixture adjustment. When activated, fuel mixture trim values are visible for the direct trim function, page 23.

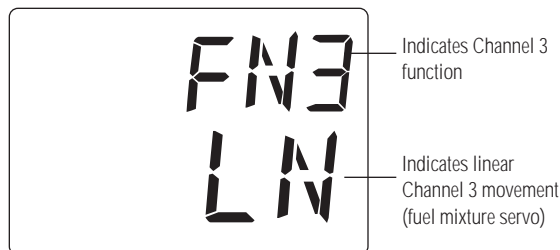

**3P** = The 3P, or 3 position, servo travel function is designed to be used as a transmission gear shift channel. This feature is designed for use only with Tamiya® vehicles equipped with

this feature. As mentioned previously, this function is accessible through the Grip Dial A. In this function, the servo's travel can be selected to only three positions: left, center and right. The left and right travel values are determined by the travel adjust function, page 18. The center position can be adjusted via the sub-trim function, page 21.

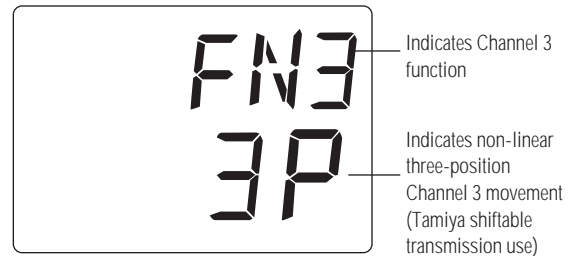

**0** = The 0, or inhibit, function is designed to be used when the brake endpoint adjustment function, page 26, is required. This function is designed to be used with most types of electric and gas-powered R/C cars. This feature is extremely popular, as it allows the amount of braking accessible through the throttle trigger's forward position to be adjusted during operation for maximum effectiveness. When activated, the braking valves will be visible via the direct trim function, page 23.

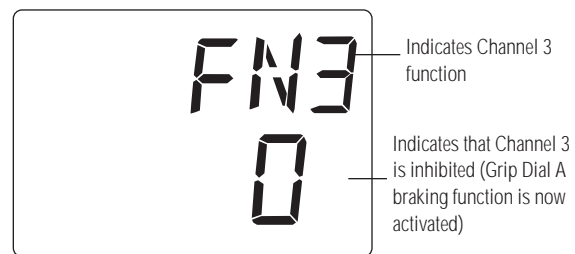

## Accessing the Channel 3 Function

To access the Channel 3 function, follow the steps below:

Press and hold the MODE and CHANNEL keys at the same time to enter the System Mode. Next, press the MODE key twice until FN3 appears

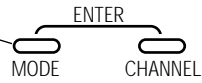

Press the INCREASE or DECREASE keys to select the Channel 3 function type to be used

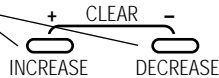

LN= Linear servo movement

3P= 3 position servo movement

0= Inhibited (grip dial A braking is now active)

1. Press the MODE and CHANNEL keys at the same time and hold.
2. Turn on the transmitter power switch to enter the System Mode.
3. MD1 should now be present on the screen. Press the MODE key twice until FN3 appears on the screen.
4. Press the INCREASE or DECREASE keys to select the correct Channel 3 function type to be used.
5. To access the model select function, press the MODE key. To exit the System Mode, either turn the transmitter power switch off or press the MODE and CHANNEL keys at the same time.

# Accessing the Function Mode

To enter the function mode, it's necessary to first turn on the transmitter's power switch. Next, press the MODE key until a beep is heard. The display will change to show the first function listed on the Function Mode flow chart as shown below. Press the MODE key to scroll down through the functions

one by one, as shown in the flow chart. Once the desired function has been reached, use the channel key to select the appropriate channel (if applicable). To adjust the values of the function, simply press the INCREASE (+) or DECREASE (-) keys until the desired value is displayed on the screen.

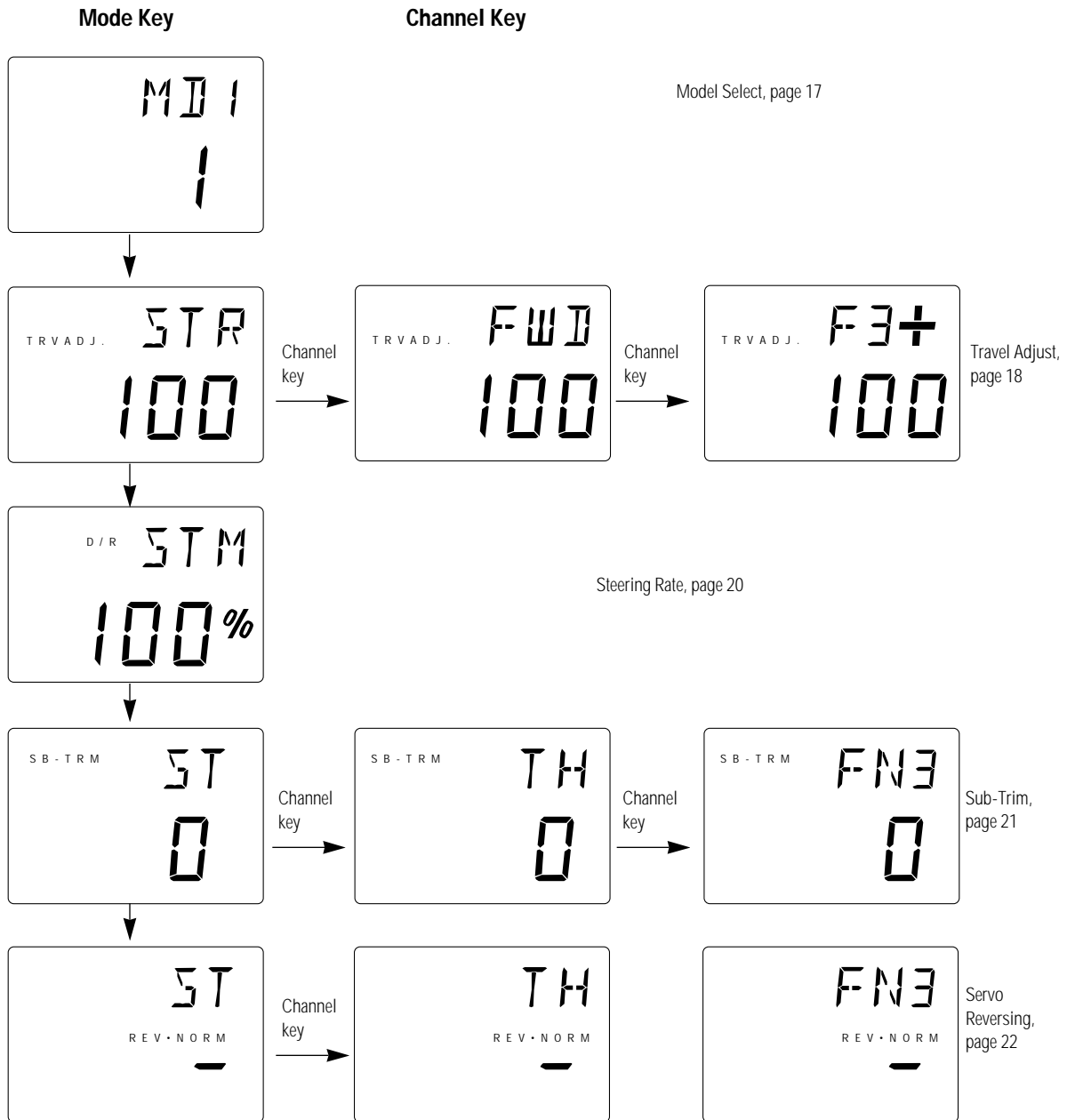

# Model Select (Function Mode)

The XR-3 has memory for three (3) models. This feature allows for three different models to be operated with the same transmitter (additional receivers and servos must be purchased separately), or one model with three (3) different race setups.

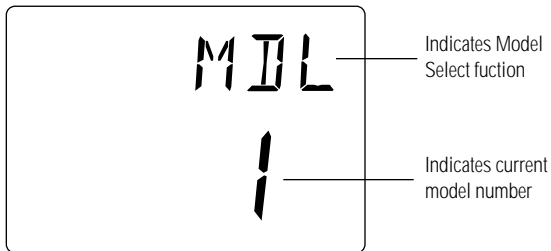

## Accessing the Model Select Function

To access the Model Select function, follow the steps below:

Press the MODE key until MDL appears on the screen

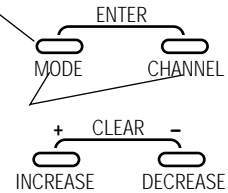

Press the INCREASE and DECREASE keys to select the desired model to be used (1, 2, or 3)

1. Turn the transmitter power switch on.
2. Press the MODE key to access the Function Mode.
3. Press the MODE key until MDL appears on the screen.
4. Press the INCREASE or DECREASE keys to select the desired model number (1, 2, or 3).
5. Press the MODE key to access the Travel Adjust function.
6. To exit the Function Mode, either turn off the transmitter power switch or press the MODE and CHANNEL keys at the same time.

# Travel Adjust (Function Mode)

The Travel Adjust feature of the XR-3 allows the maximum travel of both the steering, throttle and Channel 3 (optional) servos to be increased or decreased in each direction to achieve the exact servo movement needed. The adjustment range is from 0% to 125%. The travel adjustment is factory set to 100% for both channels. The travel adjustment value displayed on the screen depends on the current position of the steering wheel, trigger, or trim lever to be adjusted. This feature is very useful either to maximize servo travel or to

reduce servo over-travel to eliminate servo binding (servo moves further than control mechanism allows), without the need for mechanical linkage adjustment.

The screens below are accessed by turning the wheel to the desired direction to be adjusted (left or right), by moving the trigger to the forward or backward (brake) position, or by moving the Grip Lever A to the forward or back positions.

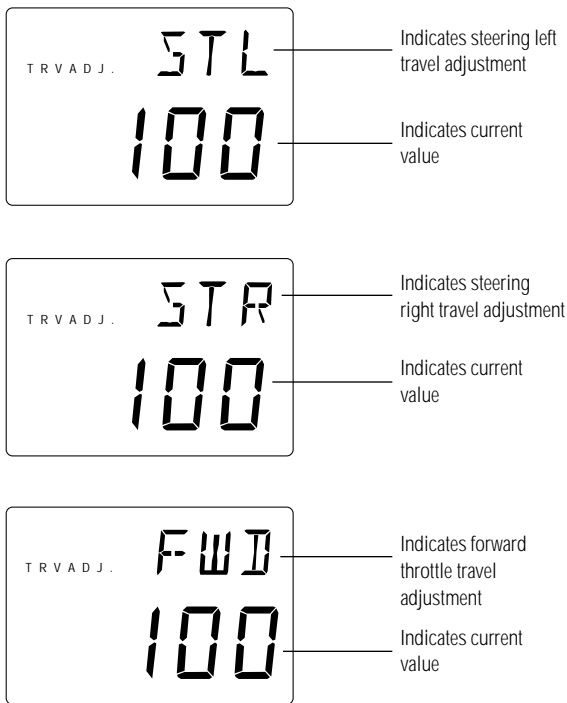

# Channel 3 Screens (Optional)

Functions **LN** & **3P**

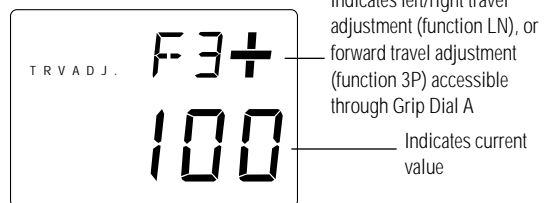

Functions **3P** only

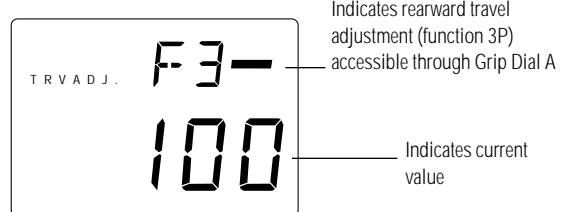

## Accessing The Travel Adjust Function

To access the Travel Adjust feature, follow the step below:

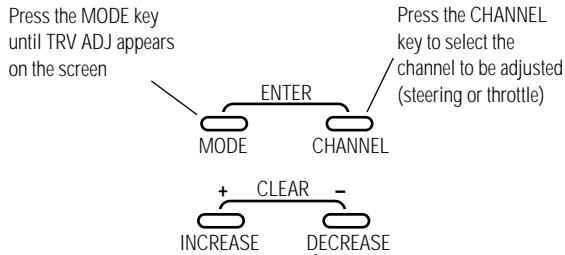

Move the wheel/trigger or Grip Lever A in the desired direction and press either the INCREASE or DECREASE keys to achieve the desired travel value

1. Turn on the transmitter power switch
- 2 Press the MODE key to enter the Function Mode.
3. Press the MODE key until TRV ADJ appears in small letters on the left side of the screen.

4. Press the CHANNEL key to select the desired channel to be adjusted. Steering = STR (steering right) or STL (steering left); Throttle = FWD (forward) or BRM (braking or reverse); Channel 3 (optional) = F3+ or F3- (function 3P only)
5. Move the steering wheel, trigger or Grip Lever A in the desired direction for adjustment (left/right, forward/reverse or brake). Press the INCREASE or DECREASE key to achieve the desired amount of travel. Move the wheel, trigger or Grip Lever A in the opposite direction to adjust the travel in the opposite direction.

**Note:** For Channel 3 function, if LN is selected, only F3+ is adjustable.

6. Press the MODE key to access the Steering Dual Rate function.
7. To exit the Function Mode, either turn off the transmitter power switch or press the MODE and CHANNEL keys at the same time.

**Note:** When setting the travel adjust values for the steering function, it's suggested that if possible the maximum travel values be set to an equal value in both directions to maintain proper steering control.

# Steering Rate (Function Mode)

The Steering Rate feature of the XR-3 allows the steering servo travel to be increased or decreased to the desired amount required. The values of the Steering Rate function are a percentage based from the travel adjust value set in the Travel Adjust section.

Example: Travel adjust value 100%, Steering value 80% — Maximum steering rate is now reduced to 80% of the maximum travel value (100%)

The Steering Rate function also works in conjunction with the Grip Lever B Steering Rate function (page 25) and acts as the maximum rate available through Grip Dial B. This feature allows the steering rate to be increased or decreased directly from the Grip Lever B while racing to maximize the steering rate needed for the particular track conditions.

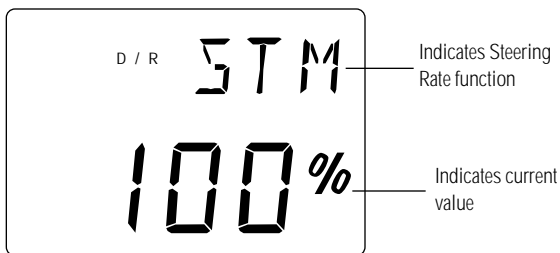

## Accessing the Steering Rate Function

To access the Steering Rate Function, follow the steps below:

Press the MODE key until D/R STM appears on the screen

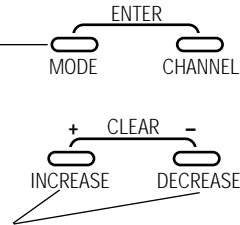

Press the INCREASE or DECREASE keys to achieve the desired steering rate value

1. Turn on the transmitter power switch.
2. Press the MODE key to enter the Function Mode.
3. Press the MODE key until D/R STM appears on the screen.
4. Press the INCREASE or DECREASE keys until the proper steering rate is achieved.
5. Press the MODE key to access the Sub-Trim function.
6. To exit the Function Mode, either turn off the transmitter power switch or press the MODE and CHANNEL keys at the same time.

## Sub-Trim (Function Mode)

The Sub-Trim function of the XR-3 is an electronic trimming feature that allows the neutral position of the servo on either the steering, throttle or third channel (optional) to be moved, while allowing the electronic trim lever for that channel to remain in the center position. This feature is very useful as it allows the servo arm/wheel position to be moved to help with control linkage installation, eliminating the need to make mechanical linkage adjustments.

Although the Sub-Trim function is a very useful feature, it is suggested that only small amounts of sub-trim be used so that no unwanted, non-equal servo travel is created. It's suggested that less than 30 points of sub-trim be used during adjustment. If more than 30 points of sub-trim are required, it's suggested that a mechanical linkage adjustment be performed.

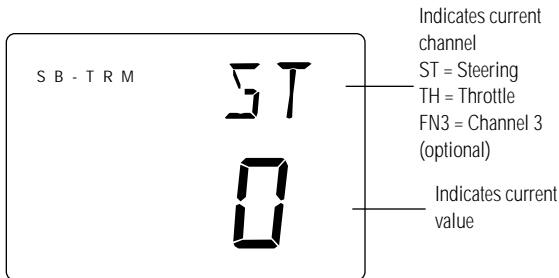

## Accessing the Sub-Trim Function

To access the Sub-Trim function, follow the steps below:

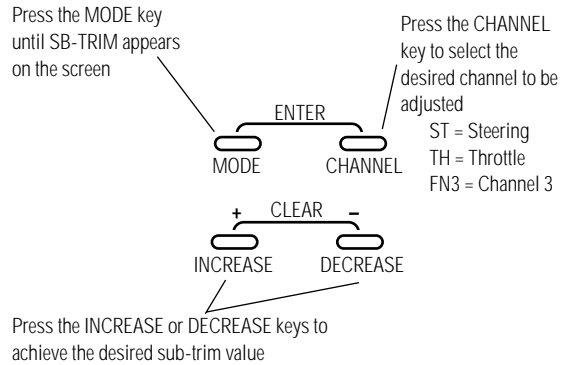

1. Turn on the transmitter power switch.
2. Press the MODE key to enter the Function Mode.
3. Press the MODE key until SB-TRIM appears in small letters to the left of the screen.
4. Press the CHANNEL key to select the channel to be adjusted (ST= Steering, TH= Throttle, FN3= Channel 3).
5. Press the INCREASE or DECREASE keys until the proper servo position is achieved.
6. Press the Mode key to access the Servo Reversing function.
7. To exit the Function Mode, either turn off the transmitter power switch or press the MODE and CHANNEL keys at the same time.

# Servo Reversing (Function Mode)

The Servo Reversing feature of the XR-3 is a very convenient feature when setting up a new model. The purpose of the servo reversing function is to change the direction of the servo rotation in relation to the wheel/trigger movement. The Servo Reversing function is available for the steering, throttle and Channel 3 of the XR-3.

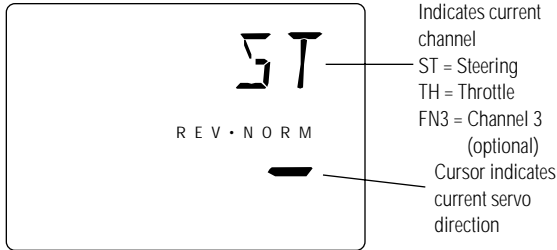

## Accessing the Servo Reversing Function

To access the Servo Reversing function, follow the steps below:

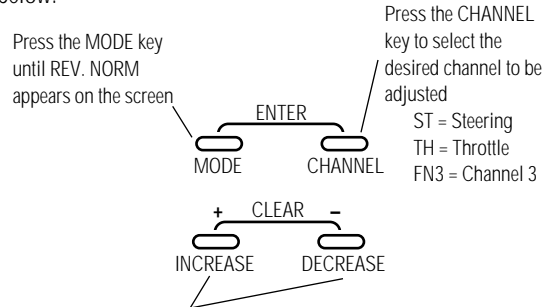

Press the INCREASE or DECREASE keys to move the cursor to the desired servo direction

1. Turn the transmitter power switch on.
2. Press the MODE key to access the Function Mode.
3. Press the MODE key until REV.NORM appears in small letters to the right of the screen.
4. Press the CHANNEL key to select the channel to be changed (ST = Steering, TH = Throttle, FN3 = Channel 3).
5. Press the INCREASE or DECREASE keys to move the cursor to the desired direction.
6. To exit the Function Mode, either turn off the transmitter power switch or press the MODE and CHANNEL keys at the same time.

# Accessing the Direct Trim Mode

The Direct Mode function of the XR-3 is accessible through the use of the electronic throttle or steering trim levers, as well as the two electronic grip levers (A&B) located on the upper portion of the grip handle. This function allows for quick trim adjustment of these controls, without the need to access these functions through the four keypad control keys.

To access the Direct Trim Mode function, turn on the transmitter power switch. Next, move the desired trim lever to be

adjusted. The appropriate screen for the selected trim lever will be displayed. To adjust, simply move the trim lever in the desired direction until the correct amount of trim is achieved. Once the desired trim is achieved, the screen will return to the Normal display screen after approximately five seconds from the last trim input. If the MODE or CHANNEL keys are pressed any time during the five seconds, the system will return to the previous screen in use.

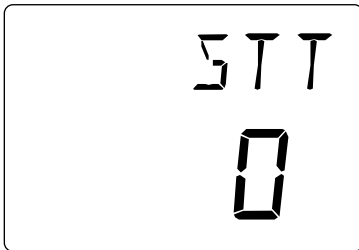

Steering Trim, page 24

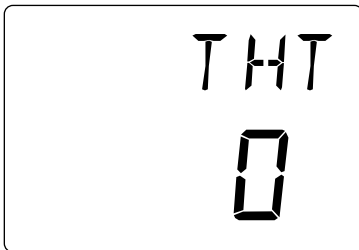

Throttle Trim, page 24

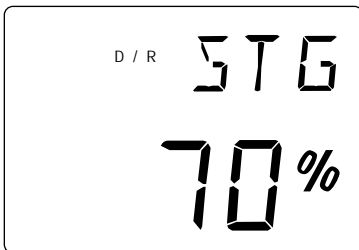

Steering Dual Rate (Grip Lever B), page 25

Only present when 3 position "0" is selected

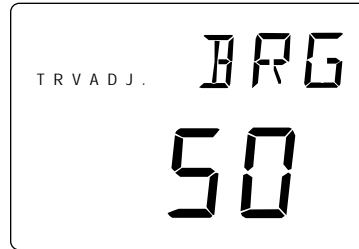

Brake Travel Adjustment (Grip Lever A), page 26 (Only visible when the Channel 3 function "0" has been selected.) Refer to Channel 3 function, page 14, for clarification

\*

Only present when 3 position "LN" is selected



Channel 3 trim adjustment (LN mode only) Refer to Channel 3 function, page 14, for clarification

\*

**\*Note:** When Channel 3 position 3P is selected, the two screens above are not present.

## Steering Trim (STT)

The XR-3 electronic steering trim lever, located just above the steering wheel, allows the center position of the servo to be manipulated in either direction to achieve precise centering of the steering assembly. Steering travel adjustment values (page 18) remain completely independent from the steering trim, unless the trim value exceeds the selected endpoint values. (For example: If trim value are set at 40 and endpoint values at 30, steering trim will override/alter the endpoint value.)

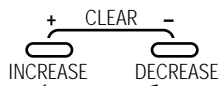
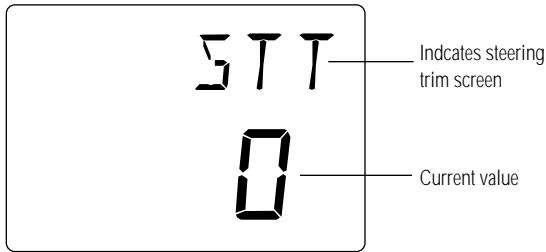

Press the INCREASE and DECREASE keys at the same time to reset the steering trim to zero

To adjust the steering trim servo position, move the electronic steering trim lever either to the left (+) or the right (-). As soon as the trim is moved, the STT steering trim screen will appear, and will continue to be displayed unless the trim lever is untouched for a period of five seconds. To reset the trim value to 0, press the INCREASE and DECREASE keys at the same time while the STT screen is displayed.

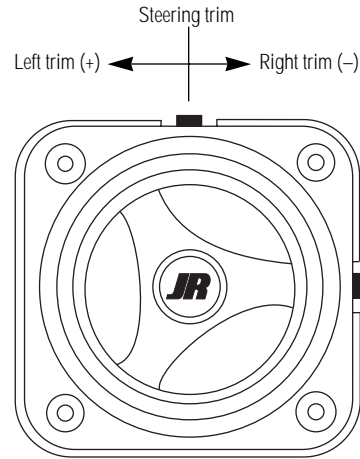

Steering Trim Location

## Throttle Trim (THT)

The XR-3's electronic throttle trim lever, located to the right of the steering wheel, allows the center position of the servo to be manipulated in either direction to achieve precise centering of the throttle trigger neutral position. Throttle endpoint adjustment values (page 18) remain completely independent from the throttle trim, unless the trim value exceeds the selected endpoint values. (For example: If the trim value is set at 40 and the endpoint values at 30, throttle trim will override/alter the endpoint value.)

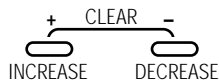
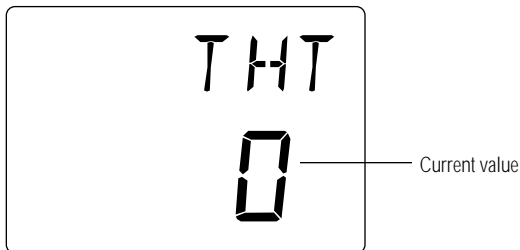

Press the INCREASE and DECREASE keys at the same time to reset the throttle trim value to zero

To adjust the throttle trim servo position, move the electronic steering trim lever either up (+) or down (-). As soon as the trim is moved, the THT throttle trim screen will appear and will continue to be displayed unless the trim lever is untouched for a period of five seconds. To reset the trim value to zero, press the INCREASE and DECREASE keys at the same time while the THT screen is displayed.

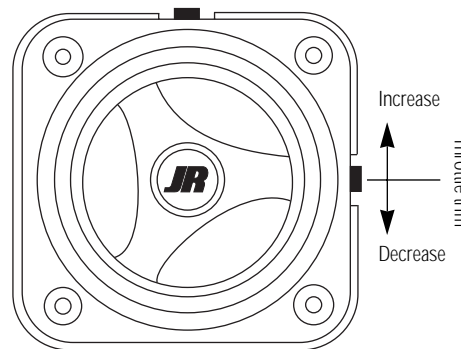

Throttle Trim Location

# Grip Lever B: Steering Dual Rate Trim Adjustment STG

The steering dual rate adjustment, located at Grip Lever B, allows the dual rate value (maximum servo travel) to be increased or decreased within a range from 100% through 40% of the total dual rate value established in the Steering Rate function (page 20). This function is very useful in race conditions as it allows you to custom tailor the steering radius and sensitivity for the current track conditions.

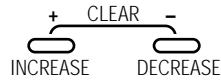
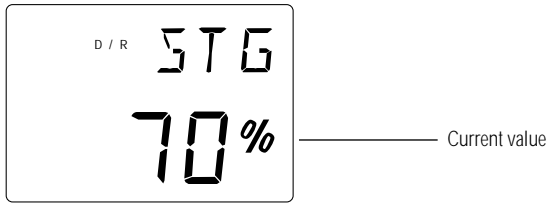

Press the INCREASE and DECREASE keys at the same time to reset the steering dual rate trim to the factory preset (70%)

Please note that since the dual rate value shown in the STG screen is the percentage of the value established in the Steering Rate function, the value will not always increase or decrease, or beep once for each time the Grip Lever B is moved.

To adjust the steering dual rate value, move the electronic Grip Lever B either left (-) or right (+). As soon as the trim is moved, the STG steering dual rate screen will appear and will continue to be displayed unless the Grip Lever B is untouched for a period of five seconds. To reset the trim value to the factory preset setting of 70%, press the INCREASE and DECREASE keys at the same time while the STG screen is displayed.

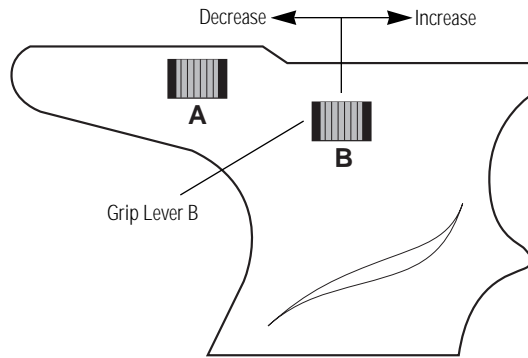

# Grip Lever A: Brake Endpoint Adjustment BRG/Channel 3

## Access Brake Endpoint Adjustment

The brake endpoint adjustment, located at Grip Lever A, allows the maximum servo travel on the braking side of the throttle trigger to be increased or decreased from 100% to 0% (off). This function is very useful in race conditions as it allows the racer to custom tailor the "panic" brake value to maximize the car's braking power for the current track conditions. Please note that since the brake endpoint value shown in the BRG screen is a percentage of the total braking value established in the Travel Adjust function (page 18), the value will not always increase or decrease, or beep once for each time the Grip Lever A is moved.

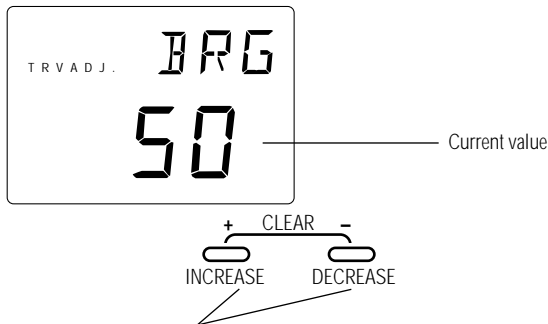

Press the INCREASE and DECREASE keys at the same time to reset the brake endpoint trim value to the factory preset (50%)

To adjust the brake endpoint value, move the electronic Grip Lever A either left (-) or right (+). As soon as the grip lever is moved, the BRG Travel Adjust screen will appear and will continue to be displayed unless the Grip Lever A is untouched for a period of five seconds. To reset the brake endpoint value to the factory preset setting of 50%, press the INCREASE and DECREASE keys at the same time while the BRG screen is displayed.

Diagram A

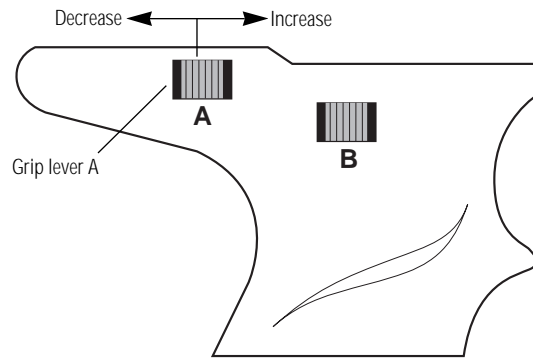

Move the grip lever A to the left or right to decrease or increase values

## Channel 3 Access (Fuel Mixture)

When selected, the Grip Lever A can also be used to access the Channel 3 function of the XR-3 for use as a fuel mixture Channel 3 transmission shift selector.

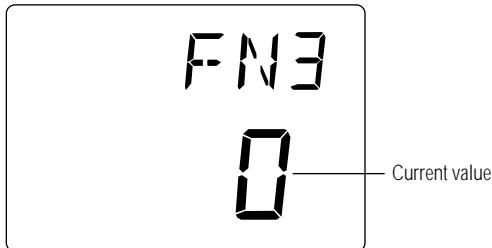

When the LN (linear) Channel 3 function is selected, the Grip Lever A can be used to change the neutral position of the servo to lean or richen the engine's fuel mixture. Once the desired fuel mixture has been achieved, the Grip Lever A value indicated on this screen can be transferred manually to the sub-trim function (page 21) and the value of the FN3 screen can be returned to zero. Please refer to diagram A below for proper grip lever operation.

## Channel 3 Transmission Shift Selector (Specific Tamiya® Vehicles Only)

When the 3P channel function is selected, the Grip Lever A can be used to move the 3 Channel servo to a maximum of three positions (left, center, right, and gear 1, 2 and 3.) When the 3P function is selected, there will be no Direct Trim Access screen present as with previous functions. Please refer to diagram A at right for proper shifting procedures.

**Note:** As mentioned previously, in this function, the travel adjust function is used to set the first and second gear servo travel positions, while the sub-trim feature is used to adjust the second gear (servo neutral) position. Please refer to these sections for clarification.

Diagram A

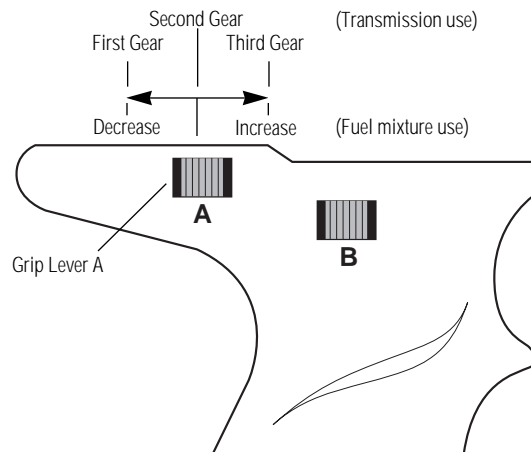

Please note that to remain in either first or third gears, it's necessary to hold the Grip Lever A in the desired position. If the grip lever is released, the transmission will return to the second (center) gear position.

# XR-3 Data Sheet

## System Mode

MODEL NUMBER	1	2	3
MODEL NAME			
CHANNEL THREE FUNCTION	LN	3P	0

## Function Mode

	STEERING		THROTTLE		CHANNEL 3	
TRAVEL ADJUST	STR	STL	FWD	REV	-	+
STEERING DUAL RATE	%		/		/	
SUB-TRIM						
SERVO REVERSING	REV. NORM		REV. NORM		REV. NORM	

## Direct Mode

TRIM VALUES	STEERING -/+	THROTTLE -/+	CHANNEL 3 -/+
GRIP LEVER B STEERING D/R	%		/
GRIP LEVER A VALUES	BRAKE TRAVEL ADJUST	OR	CHANNEL 3 FUNCTION "LN"
	%		-/+

## System Mode

MODEL NUMBER	1	2	3
MODEL NAME			
CHANNEL THREE FUNCTION	LN	3P	0

## Function Mode

	STEERING		THROTTLE		CHANNEL 3	
TRAVEL ADJUST	STR	STL	FWD	REV	-	+
STEERING DUAL RATE	%		/		/	
SUB-TRIM						
SERVO REVERSING	REV. NORM		REV. NORM		REV. NORM	

## Direct Mode

TRIM VALUES	STEERING -/+	THROTTLE -/+	CHANNEL 3 -/+
GRIP LEVER B STEERING D/R	%		/
GRIP LEVER A VALUES	BRAKE TRAVEL ADJUST	OR	CHANNEL 3 FUNCTION "LN"
	%		-/+

# XR-3 Data Sheet

## System Mode

MODEL NUMBER	1	2	3
MODEL NAME			
CHANNEL THREE FUNCTION	LN	3P	0

## Function Mode

	STEERING		THROTTLE		CHANNEL 3	
TRAVEL ADJUST	STR	STL	FWD	REV	-	+
STEERING DUAL RATE	%		/		/	
SUB-TRIM						
SERVO REVERSING	REV. NORM		REV. NORM		REV. NORM	

## Direct Mode

TRIM VALUES	STEERING -/+	THROTTLE -/+	CHANNEL 3 -/+
GRIP LEVER B STEERING D/R	%		/
GRIP LEVER A VALUES	BRAKE TRAVEL ADJUST	OR	CHANNEL 3 FUNCTION "LN"
	%		-/+

# Frequency Chart

VIII. FREQUENCY CHART					
FREQUENCY (MHz)	CHANNEL	FREQUENCY (MHz)	CHANNEL	FREQUENCY (MHz)	CHANNEL
26.995.....	1	75.530.....	67	75.770.....	79
27.045.....	2	.550.....	68	.790.....	80
.095.....	3	.570.....	69	.810.....	81
.145.....	4	.590.....	70	.830.....	82
.195.....	5	.610.....	71	.850.....	83
.255.....	6	.630.....	72	.870.....	84
75.410.....	.61	.650.....	73	.890.....	85
.430.....	.62	.670.....	74	.910.....	86
.450.....	.63	.690.....	75	.930.....	87
.470.....	.64	.710.....	76	.950.....	88
.490.....	.65	.730.....	77	.970.....	89
.510.....	.66	.750.....	78	.990.....	90

# Warranty And Service Information

**Important Note:** Be sure to keep your original dated sales receipt in a safe place as you will be required to provide proof of purchase date for the equipment to be serviced under warranty.

## Warranty Coverage

Your new JR Remote Control Radio System is warranted to the original purchaser against manufacturer defects in material and workmanship for 365 days from the date of purchase. During this period, Horizon Service Center will repair or replace, at our discretion and at no cost to the purchaser, any component that is found to be factory defective. This warranty is limited to the original purchaser of the unit and is not transferable.

This warranty does not apply to any unit which has been improperly installed, mishandled, abused or damaged in a crash, or to any unit which has been repaired or altered by any unauthorized agencies. Under no circumstances will the buyer be entitled to consequential or incidental damages. This limited warranty gives you specific legal rights; you also have other rights which may vary from state to state. As with all fine electronic equipment, do not subject your radio system to extreme temperatures, humidity or moisture. Do not leave it in direct sunlight for long periods of time.

## Repair Service Directions

In the event that your JR radio needs service, please follow the instructions listed below.

1. Check all on/off switches to be sure they are off. This will speed the repair process of checking battery condition.
2. Return your system components only (transmitter, receiver, servos, etc.). Do not return your system installed in a model car, boat, etc.

3. Preferably, use the original carton/packaging (molded foam container), or equivalent, to ship your system. Do not use the system carton itself as a shipping carton—you should package the system carton within a sturdy shipping container using additional packing material to safeguard against damage during transit. Include complete name and address information inside the carton, as well as clearly writing it on the outer label/return address area.

4. Include detailed information explaining your operation of the system and problem(s) encountered. Provide an itemized list of equipment enclosed and identify any particular area/function which may better assist our technicians in addressing your concerns. Date your correspondence and be sure your complete name and address appear on this enclosure.

5. Include you name, mailing address, and a phone number where you can be reached during the business day.

6. **Warranty Repairs.** To receive warranty service you must include your original dated sales receipt to verify your proof-of-purchase date. Providing that warranty conditions have been met, your radio will be repaired without charge.

7. **Normal Non-Warranty Repairs.** Should your repair cost exceed 50% of the retail purchase cost, you will be provided with an estimate advising you of your options.

Within your letter, advise us of the payment method you prefer to use. The Horizon Service Center accepts only VISA or MasterCard. Please include your card number and expiration date.

Mail your system to: **Horizon Service Center  
4105 Fieldstone Road  
Champaign, IL 61822  
Phone: (217) 355-9511**

